



**RE SERIES**  
**E<sup>4</sup> ELECTRIC FRYERS**  
**Service & Parts Manual**



Frymaster, a member of the Commercial Food Equipment Service Association, recommends using CFESA Certified Technicians.

**24-Hour Service Hotline 1-800-551-8633**

[www.frymaster.com](http://www.frymaster.com)

E-mail: [service@frymaster.com](mailto:service@frymaster.com)

MAY 2009  
\* 8196150 \*

**NOTICE**

IF, DURING THE WARRANTY PERIOD, THE CUSTOMER USES A PART FOR THIS ENODIS EQUIPMENT OTHER THAN AN UNMODIFIED NEW OR RECYCLED PART PURCHASED DIRECTLY FROM FRYMASTER DEAN, OR ANY OF ITS AUTHORIZED SERVICE CENTERS, AND/OR THE PART BEING USED IS MODIFIED FROM ITS ORIGINAL CONFIGURATION, THIS WARRANTY WILL BE VOID. FURTHER, FRYMASTER DEAN AND ITS AFFILIATES WILL NOT BE LIABLE FOR ANY CLAIMS, DAMAGES OR EXPENSES INCURRED BY THE CUSTOMER WHICH ARISE DIRECTLY OR INDIRECTLY, IN WHOLE OR IN PART, DUE TO THE INSTALLATION OF ANY MODIFIED PART AND/OR PART RECEIVED FROM AN UNAUTHORIZED SERVICE CENTER.

**⚠ DANGER**

Copper wire suitable for at least 167°F (75°C) must be used for power connections.

**⚠ DANGER**

The electrical power supply for this appliance must be the same as indicated on the rating and serial number plate located on the inside of the fryer door.

**⚠ DANGER**

This appliance must be connected to the voltage and phase as specified on the rating and serial number plate located on the inside of the fryer door.

**⚠ DANGER**

All wiring connections for this appliance must be made in accordance with the wiring diagrams furnished with the equipment. Wiring diagrams are located on the inside of the fryer door.

**⚠ DANGER**

Do not store or use gasoline or other flammable vapors and liquids in the vicinity of this or any other appliance.

**⚠ WARNING**

Do not attach accessories to this fryer unless fryer is secured from tipping. Personal injury may result.

**⚠ WARNING**

Frymaster fryers equipped with legs are for permanent installations. Fryers fitted with legs must be lifted during movement to avoid damage and possible bodily injury. For a moveable or portable installation, Frymaster optional equipment casters must be used. Questions? Call 1-800-551-8633 or email at [service@frymaster.com](mailto:service@frymaster.com).

**⚠ WARNING**

Do not use water jets to clean this equipment.

**⚠ WARNING**

This equipment is intended for indoor use only. Do not install or operate this equipment in outdoor areas.

**⚠ DANGER**

Adequate means must be provided to limit the movement of this appliance without depending on or transmitting stress to the electrical conduit. A restraint kit is provided with the fryer. If the restraint kit is missing contact your local Frymaster Factory Authorized Service Center (FASC) for part number 826-0900.

**⚠ DANGER**

Prior to movement, testing, maintenance and any repair on your Frymaster fryer, disconnect all electrical power from the fryer.

**ELECTRICAL POWER SPECIFICATIONS**

Three (3) Phase Requirements								
kW	VOLTAGE	PHASE	WIRE SERVICE	MINIMUM SIZE		AMPS PER LEG		
				AWG	mm <sup>2</sup>	L1	L2	L3
14	208	3	3	6	16	39	39	39
14	240	3	3	6	16	34	34	34
14	480	3	3	8	10	17	17	17
14	220/380	3	4	6	16	21	21	21
14	240/415	3	4	6	16	20	20	21
14	230/400	3	4	6	16	21	21	21
ALL EPRI 14kW (SOLID STATE)	208	3	3	6	16	39	39	39
	240	3	3	6	16	34	34	34
	220/380	3	4	6	16	21	21	21
	240/415	3	4	6	16	20	20	20
17	208	3	3	6	16	48	48	48
17	240	3	3	6	16	41	41	41
17	480	3	3	6	16	21	21	21
17	220/380	3	4	6	16	26	26	26
17	240/415	3	4	6	16	24	24	24
17	230/400	3	4	6	16	25	25	25
ALL EPRI 17kW (SOLID STATE)	208	3	3	6	16	48	48	48
	240	3	3	6	16	41	41	41
	220/380	3	4	6	16	26	26	26
	240/415	3	4	6	16	24	24	24
22	208	3	3	4	25	61	61	61
22	240	3	3	4	25	53	53	53
22	480	3	3	6	16	27	27	27
22	220/380	3	4	6	16	34	34	34
22	240/415	3	4	6	16	31	31	31
22	230/400	3	4	6	16	32	32	32

Single Phase Requirements						
kW	VOLTAGE	PHASE	WIRE SERVICE	MINIMUM SIZE		AMPS
				AWG	mm <sup>2</sup>	
14	208	1	2	3	34	68
14	240	1	2	4	25	59
14	480	1	2	8	10	30

# RE SERIES E<sup>4</sup> ELECTRIC FRYERS

## TABLE OF CONTENTS

---

<b>CAUTIONARY STATEMENTS</b> .....	i
<b>ELECTRICAL POWER SPECIFICATIONS</b> .....	ii
<b>CHAPTER 1: Service Procedures</b>	
1.1 General .....	1-1
1.2 Replacing a Controller.....	1-1
1.3 Replacing Component Box Components .....	1-1
1.4 Replacing a High-Limit Thermostat.....	1-3
1.5 Replacing a Temperature Probe .....	1-3
1.6 Replacing a Heating Element .....	1-5
1.7 Replacing Contactor Box Components .....	1-6
1.8 Replacing a Frypot .....	1-7
1.9 Built-In Filtration System Service Procedures.....	1-9
1.9.1 Filtration System Problem Resolution .....	1-9
1.9.2 Replacing the Filter Motor, Filter Pump and Related Components .....	1-10
1.9.3 Replacing the Filter Transformer or Filter Relay .....	1-12
1.10 Basket Lift Service Procedures .....	1-12
1.11 Interface Board Diagnostic Chart.....	1-15
1.12 Probe Resistance Chart.....	1-16
1.13 Wiring Diagrams .....	1-17
1.13.1.1 Basket Lift Wiring 208-250V.....	1-17
1.13.1.2 Basket Lift Wiring 100-120V.....	1-18
1.13.2.1 Component Wiring Standard.....	1-19
1.13.2.2 Component Wiring Fryer and Half .....	1-20
1.13.3 Tilt Switch Wiring.....	1-21
1.13.4 Component Wiring – Fast Ready .....	1-22
1.13.5 Fast Ready Computer Wiring.....	1-23
1.13.6 Fast Ready Computer Harness Wiring.....	1-24
1.13.7 Fast Ready Control Wiring.....	1-25
1.13.8 Contactor Box-Delta Configuration .....	1-26
1.13.9 Contactor Box-WYE Configuration.....	1-28
1.13.10 Terminal Block Wiring .....	1-29
1.13.11 Oil Disposal Wiring.....	1-30
1.13.12 Simplified RE14/17/22 Full-Vat Delta Wiring .....	1-31
1.13.13 Simplified RE14/17/22 Dual-Vat Delta Wiring.....	1-32
1.13.14 Simplified RE14/17/22 Full-Vat Export WYE Wiring.....	1-33
1.13.15 Simplified RE14/17/22 Dual-Vat Export WYE Wiring.....	1-34
1.13.16 Simplified RE14/17/22 Full-Vat EPRI Wiring .....	1-35
1.13.17 Simplified RE14/17/22 Full-Vat EPRI Export WYE Wiring .....	1-36
<b>CHAPTER 2: Parts List</b>	
2.1 Accessories .....	2-1
2.2 Basket Lift Assembly and Associated Parts.....	2-2
2.3 Cabinetry .....	2-4
2.3.1 Backs, Control Panel Frames, Doors, Sides, Tilt Housings and Top Caps.....	2-4
2.3.2 Cabinet Bases, Braces and Associated Parts .....	2-7
2.4 Drain System Components .....	2-9
2.4.1 Drain Tube Sections and Associated Parts.....	2-9
2.4.2 Drain Valves and Associated Parts (Units with Built-In Filtration) .....	2-11

**RE SERIES E<sup>4</sup> ELECTRIC FRYERS  
TABLE OF CONTENTS cont.**

---

2.4.3	Drain Valves and Associated Parts (Units without Built-In Filtration) .....	2-15
2.5	Electronics and Electrical Components.....	2-16
2.5.1	Component Boxes .....	2-16
2.5.2	Contactors Boxes .....	2-18
2.5.3	Fuse Boxes .....	2-22
2.5.4	Terminal Blocks .....	2-23
2.5.5	Heating Element Assemblies and Associated Parts .....	2-24
	2.5.5.1 Element Assemblies and Hardware.....	2-24
	2.5.5.2 Element Tube Assemblies .....	2-26
2.5.6	Controllers .....	2-27
2.5.7	Wiring.....	2-28
	2.5.7.1 Contactor Box Wiring Assemblies 12-Pin Dual Vat.....	2-28
	2.5.7.2 Contactor Box Wiring Assemblies 12-Pin Full Vat.....	2-29
	2.5.7.3 Contactor Box Wiring Assemblies 6-Pin Left Element .....	2-30
	2.5.7.4 Contactor Box Wiring Assemblies 9-Pin Right Element.....	2-30
	2.5.7.5 Main Wiring Harnesses .....	2-31
	2.5.7.6 Component Box, Filter Pump and Basket Lift Wiring Harnesses ...	2-33
	2.5.7.7 Component Box to Filter Pump Harness.....	2-34
	2.5.7.8 Basket Lift Harness .....	2-34
	2.5.7.9 Interface Board to Controller Wiring Harness 15-Pin.....	2-34
2.6	Filtration System Components .....	2-35
2.7	Frypots and Associated Components .....	2-38
2.8	Oil Return System Components .....	2-40
2.9	Oil Disposal Plumbing .....	2-42
2.10	Oil Disposal Wand .....	2-43
2.11	Wiring and Pin Connectors .....	2-44
2.12	Fasteners.....	2-45

# RE SERIES E<sup>4</sup> ELECTRIC FRYERS

## CHAPTER 1: SERVICE PROCEDURES

---

### 1.1 General

Before performing any maintenance on your Frymaster fryer, disconnect the fryer from the electrical power supply.

When electrical wires are disconnected, it is recommended that they be marked in such a way as to facilitate re-assembly.

### 1.2 Replacing a Controller

1. Disconnect the fryer from the electrical power supply.
2. The controller bezel is held in place by tabs at the top and bottom. Slide the metal bezel up to disengage the lower tabs. Then slide the bezel down to disengage the upper tabs.
3. Remove the two screws from the upper corners of the control panel. The control panel is hinged at the bottom and swings open from the top.
4. Unplug the wiring harness from the connector on the back of the controller and disconnect the grounding wire from terminal adjacent to the connector. Remove the control panel assembly by lifting it from the hinged slots in the control panel frame.



5. Remove the controller from the control panel assembly and install the replacement controller. Reinstall the control panel assembly by reversing steps 1 and 2.

### 1.3 Replacing Component Box Components

1. Disconnect the fryer from the electrical power supply.
2. The controller bezel is held in place by tabs at the top and bottom. Slide the metal bezel up to disengage the lower tabs. Then slide the bezel down to disengage the upper tabs.

3. Remove the two screws from the upper corners of the control panel and allow the control panel to swing down.
4. Unplug the wiring harness from the 15-pin connector on the interface board and disconnect the grounding wire from terminal adjacent to the 15-pin connector on the back of the controller. Remove the control panel assembly by lifting it from the hinge slots in the control panel frame.
5. Disconnect the wiring from the component to be replaced, being sure to make a note of where each wire was connected.
6. Dismount the component to be replaced and install the new component, being sure that any required spacers, insulation, washers, etc. are in place.

**NOTE:** If more room to work is required, the control panel frame assembly may be removed by removing the hex head screws that secure it to the fryer cabinet (see illustration below). If this option is chosen, all control panel assemblies must be removed per steps 1 and 2 above. The cover plate on the lower front of the component box may also be removed if desired. *Removing the component box itself from the fryer is not recommended due to the difficulty involved in disconnecting and reconnecting the oil-return valve rods, which pass through openings in the component box.*

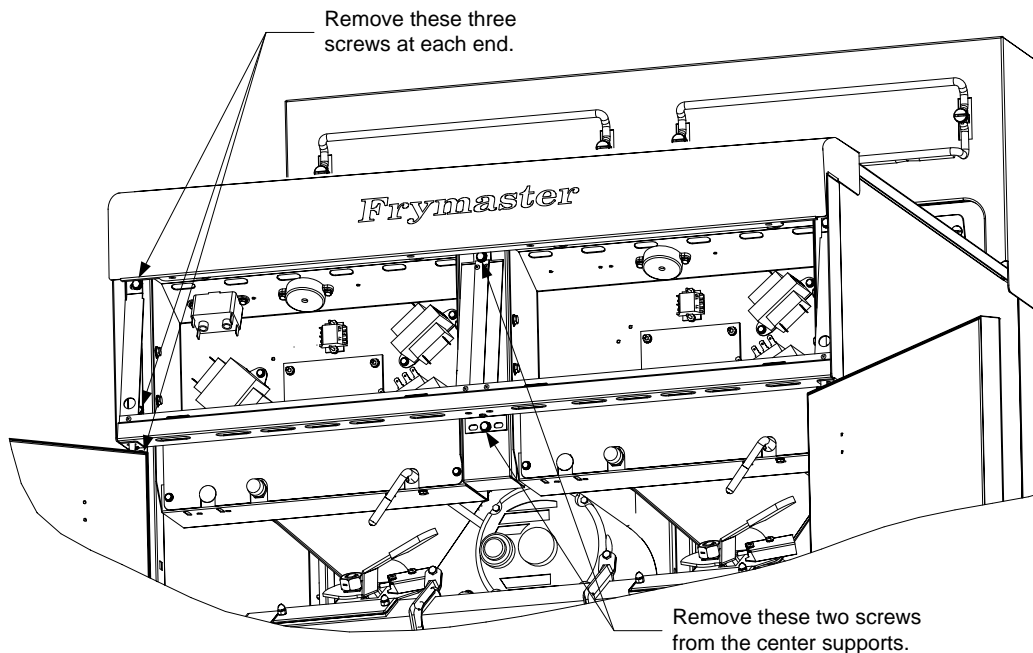

**Removing the Control Panel Frame and Top Cap Assembly**

7. Reconnect the wiring disconnected in Step 3, referring to your notes and the wiring diagrams on the fryer door to ensure that the connections are properly made. Also, verify that no other wiring was disconnected accidentally during the replacement process.
8. Reverse steps 1 through 4 to complete the replacement and return the fryer to service.

## 1.4 Replacing a High-Limit Thermostat

1. Remove the filter pan and lid from the unit. Drain the frypots into a Shortening Disposal Unit (SDU) or other appropriate metal container.



**DANGER**

**DO NOT drain more than one full frypot or two split frypots into the SDU at one time.**

2. Disconnect the fryer from the electrical power supply and reposition it to gain access to the rear of the fryer.
3. Remove the four screws from both the left and right sides of the lower back panel.
4. Locate the high-limit that is being replaced and follow the two-black wires to the 12-pin connector C-6. Note where the leads are connected prior to removing them from the connector. Unplug the 12-pin connector C-6 and using a pin-pusher push the pins of the high-limit out of the connector.
5. Using a wrench, carefully unscrew the high-limit thermostat to be replaced.
6. Apply Loctite™ PST 567 or equivalent sealant to the threads of the replacement and screw it securely into the frypot.
7. Insert the leads into the 12-pin connector C-6 (see illustration below). For full-vat units or the left half of a dual-vat unit (as viewed from the rear of the fryer) the leads go into positions 1 and 2 of the connector. For the right half of a dual-vat unit (as viewed from the rear of the fryer), the leads go into positions 7 and 8. In either case, polarity does not matter.

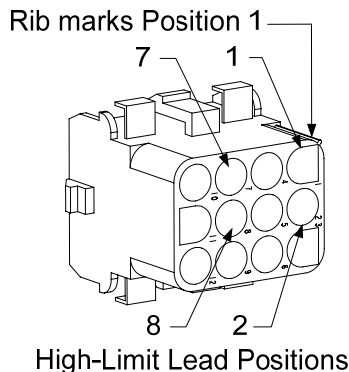

8. Reconnect the 12-pin connecting plug C-6. Use wire ties to secure any loose wires.
9. Reinstall the back panels reposition the fryer under the exhaust hood, and reconnect it to the electrical power supply to return the fryer to service.

## 1.5 Replacing a Temperature Probe

1. Remove the filter pan and lid from the unit. Drain the frypots into a Shortening Disposal Unit (SDU) or other appropriate metal container.



**DANGER**

**DO NOT drain more than one full frypot or two split frypots into the SDU at one time.**

2. Disconnect the fryer from the electrical power supply and reposition it to gain access to the rear of the fryer.
3. Remove the four screws from both sides of the lower back panel. Then remove the two screws on both the left and right sides of the back of the tilt housing. Lift the tilt housing straight up to remove from the fryer.
4. Locate the red and white wires of the temperature probe to be replaced. Note where the leads are connected prior to removing them from the connector. Unplug the 12-pin connector C-6 and using a pin-pusher push the pins of the temperature probe out of the connector.
5. Raise the element and remove the securing probe bracket and metal tie wraps that secure the probe to the element (see illustration below).

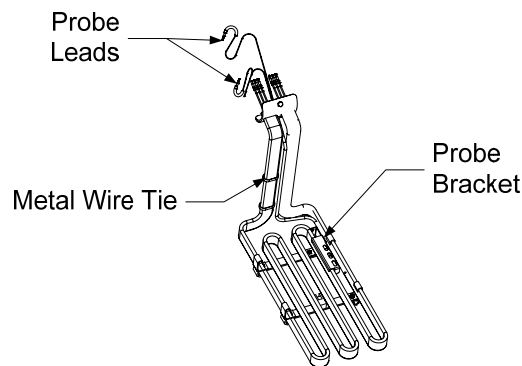

6. Gently pull on the temperature probe and grommet, pulling the wires up the rear of the fryer and through the element tube assembly.
7. Insert the replacement temperature probe (wires first) into the tube assembly ensuring that the grommet is in place. Secure the probe to the elements using the bracket which was removed in Step 5 and the metal tie wraps which were included in the replacement kit.
8. Route the probe wires out of the tube assembly following the element wires down the back of the fryer through the Heyco bushings to the 12-pin connector C-6. Secure the wires to the sheathing with wire ties.
9. Insert the temperature probe leads into the 12-pin connector C-6 (see illustration below). For full-vat units or the right half of a dual-vat unit (as viewed from the rear of the fryer) the red lead goes into position 3 and the white lead into position 4 of the connector. For the left half of a dual-vat unit (as viewed from the rear of the fryer), the red lead goes into position 9 and the white lead into position 10. **NOTE: *Right* and *left*** refer to the fryer as viewed from the rear.

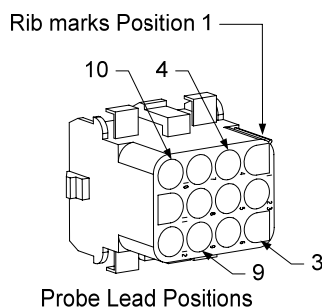

10. Secure any loose wires with wire ties making sure that the lead wires will not interfere with the movement of the springs. Rotate the elements up and down making sure that movement is not restricted and that the wires are not pinched.
11. Reinstall the tilt housing and back panels, reposition the fryer under the exhaust hood, and reconnect it to the electrical power supply to return the fryer to service.

## 1.6 Replacing a Heating Element

1. Perform steps 1-3 of section 1.5, *Replacing a Temperature Probe*.
2. On dual-vat fryers, and on full-vat fryers where the temperature probe is attached to the element being replaced, disconnect the wire harness containing the probe wiring. Using a pin pusher, disconnect the probe wires from the 12-pin connector C-6.
3. In the rear of the fryer directly behind the frypot disconnect the 6-pin connector for the left element (as viewed from the front of the fryer) or the 9-pin connector for the right element. Press in on the tabs on each side of the connector while pulling outward on the free end to extend the connector and release the element leads (see photo below). Pull the leads out of the connector and out of the wire sleeving.

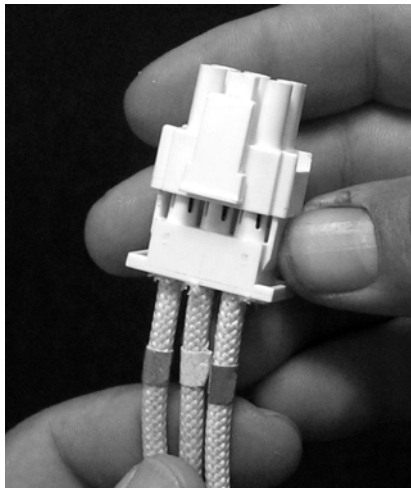

4. Raise the element to the full up position and support the elements.
5. Remove the hex head screws and nuts that secure the element to the tube assembly and pull the element out of the frypot. **NOTE:** Full-vat elements consist of two dual-vat elements clamped together. For full-vat units, remove the element clamps before removing the nuts and screws that secure the element to the tube assembly.
6. If applicable, recover the probe bracket and probe from the element being replaced and install them on the replacement element. Install the replacement element in the frypot, securing it with the nuts and screws removed in Step 5 to the tube assembly. Ensure the gasket is between the tube and element assembly.
7. Route the element leads through the element tube assembly and into the wire sleeving to prevent chafing. Ensure that the wire sleeving is routed back through the Heyco bushing keeping it clear

from the lift springs. Also ensure that the wire sleeving extends into the tube assembly to prevent the edge of the tube assembly from chafing the wires. Press the pins into the connector in accordance with the diagram on the following page, and then close the connector to lock the leads in place. **NOTE:** It is critical that the wires be routed through the sleeving to prevent chafing.

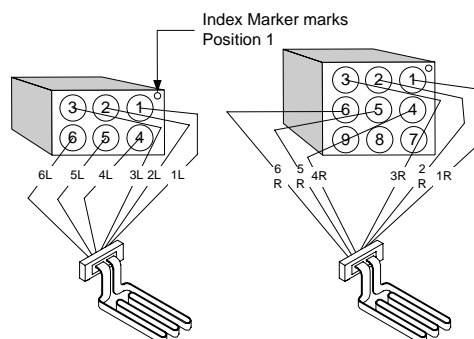

8. Reconnect the element connector ensuring that the latches lock.
9. Insert the temperature probe leads into the 12-pin wiring harness connector C-6 (see illustration below). For full-vat units or the right half of a dual-vat unit, the red lead goes into position 3 and the white into position 4. For the left half of a dual-vat unit, the red lead goes into position 9 and the white into position 10. **NOTE:** *Right* and *left* refer to the fryer as viewed from the rear.

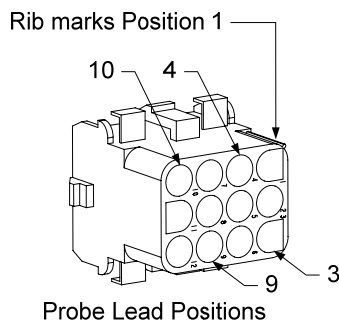

10. Reconnect the 12-pin connector C-6 of the wiring harness disconnected in Step 2.
11. Lower the element down onto the basket rack.
12. Reinstall the tilt housing and back panels, reposition the fryer under the exhaust hood, and reconnect it to the electrical power supply.

## 1.7 Replacing Contactor Box Components

1. If replacing a contactor box component above the built-in filter system, remove the filter pan and lid from the unit. Drain the frypots into a Shortening Disposal Unit (SDU) or other appropriate metal container. If replacing a contactor box component in a non-filter unit or a frypot that's not over the filter pan, drain the frypot above the box into a Shortening Disposal Unit (SDU) or other appropriate metal container.



**DANGER**

**DO NOT drain more than one full frypot or two split frypots into the SDU at one time.**

2. Disconnect the fryer from the electrical power supply.
3. Remove the two screws securing the cover of the contactor box. The contactor boxes above the filter pan are accessed by sliding under the fryer. They are located to the left and right above the guide rails (see photo below). The contactor boxes of non-filter units or frypots not over the filter pan are accessed by opening the fryer door directly under the affected frypot.

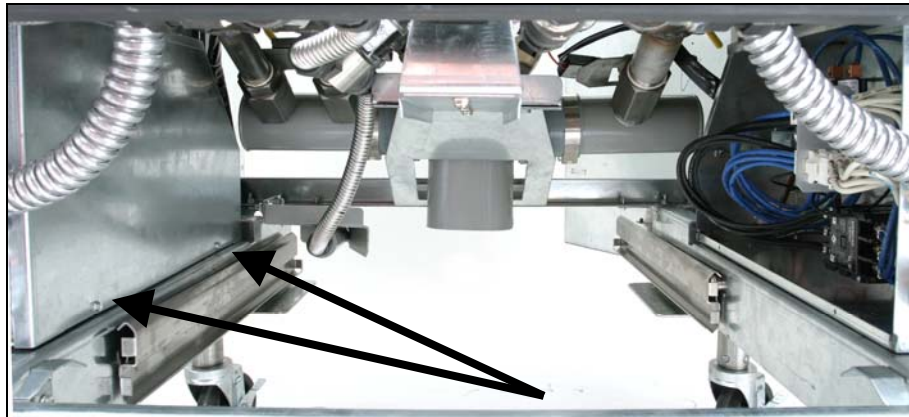

Remove two screws to access contactor box components above the filter pan.

4. The contactors and relays are held on by threaded pin studs so that only removal of the nut is required to replace the component.
5. After performing necessary service, reverse steps 1-4 to return the fryer to operation.



Left and right views of mechanical contactor box components.

## 1.8 Replacing a Frypot

1. Drain the frypot into the filter pan or, if replacing a frypot over the filter system, into a Shortening Disposal Unit (SDU) or other appropriate metal container. If replacing a frypot over the filter system, remove the filter pan and lid from the unit.



**DANGER**

**DO NOT drain more than one full frypot or two split frypots into the SDU at one time.**

2. Disconnect the fryer from the electrical power supply and reposition it to gain access to both the front and rear.

3. Slide the metal bezel up to release the bottom tabs, then slide the bezel down to disengage the upper tabs.
4. Remove the two screws from the upper corners of the control panels and allow them to swing down (see illustration and photo on page 1-1).
5. Unplug the wiring harnesses and ground wires from the backs of the controllers. Remove the controllers by lifting them from the hinge slots in the control panel frame.
6. Remove the tilt housing and back panels from the fryer. The tilt housing must be removed first in order to remove the upper back panel.
7. To remove the tilt housing remove the hex head screws from the rear edge of the housing. The housing can be lifted straight up and off the fryer.
8. Remove the control panel by removing the screw in the center and the nuts on both sides.
9. Loosen the component boxes by removing the screws, which secure them in the cabinet.
10. Dismount the top cap by removing the nuts at each end that secure it to the cabinetry.
11. Remove the hex head screw that secures the front of the frypot to the cabinet cross brace.
12. Remove the top-connecting strip that covers the joint with the adjacent frypot.
13. Unscrew the Teflon vent/vacuum-breaker tube fitting, unscrew the nut located on the front of each section of drain tube, and remove the tube assembly from the fryer.
14. Remove the covers from the drain safety switch(es) and disconnect the switch wiring at the switch(es).
15. At the rear of the fryer, unplug the 12-pin connector C-6 and, using a pin pusher, disconnect the high-limit thermostat leads.
16. Disconnect the oil return flexline(s) at the frypot end(s).
17. Raise the elements to the “up” position and disconnect the element springs.
18. Remove the machine screws and nuts that secure the element tube assembly to the frypot. Carefully lift the element assembly from the frypot and secure it to the cross brace on the rear of the fryer with wire ties or tape.
19. Carefully lift the frypot from the fryer and place it upside down on a stable work surface.
20. Recover the drain valve(s), oil return flexline connection fitting(s), and high-limit thermostat(s) from the frypot. Clean threads and apply Loctite™ PST 567 or equivalent sealant to the threads of the recovered parts and install them in the replacement frypot.
21. Carefully lower the replacement frypot into the fryer. Reinstall the hex head screw removed in step 7 to attach the frypot to the fryer.

22. Position the element tube assembly in the frypot and reinstall the machine screws and nuts removed in step 14.
23. Reconnect the oil return flexlines to the frypot, and replace aluminum tape, if necessary, to secure heater strips to the flexlines.
24. Insert the high-limit thermostat leads disconnected in step 13 (see illustration on page 1-3 for pin positions).
25. Reconnect the drain safety switch wiring to the switch(es) in accordance with the diagram below then reinstall the switch covers.

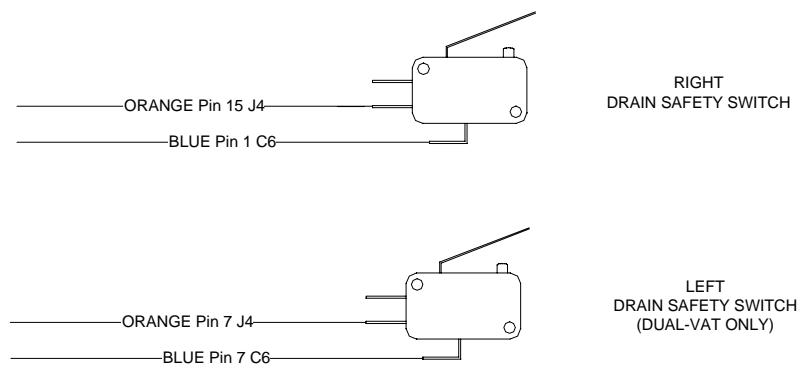

26. Reinstall the drain tube assembly.
27. Reinstall the top connecting strips, top cap, control panel, component box, tilt housing and back panels.
28. Reinstall controllers in the control panel frame and reconnect the wiring harnesses and ground wires.
29. Reposition the fryer under the exhaust hood and reconnect it to the electrical power supply.

## 1.9 Built-in Filtration System Service Procedures

### 1.9.1 Filtration System Problem Resolution

One of the most common causes of filtration problems is placing the filter paper on the bottom of the filter pan rather than over the filter screen.

**CAUTION**  
**Ensure that filter screen is in place prior to filter paper placement and filter pump operation. Improper screen placement is the primary cause of filtration system malfunction.**

Whenever the complaint is “the pump is running, but no oil is being filtered,” check the installation of the filter paper, and ensure that the correct size is being used. While you are checking the filter paper, verify that the O-rings on the pick-up tube of the filter pan are in good condition. Missing or worn O-rings allow the pump to take in air and decrease its efficiency.

If the pump motor overheats, the thermal overload will trip and the motor will not start until it is reset. If the pump motor does not start, press the red reset switch (button) located on the rear of the motor at the front of the fryer.

If the pump starts after resetting the thermal overload switch, then something is causing the motor to overheat. A major cause of overheating is when several frypots are filtered sequentially, overheating the pump and motor. Allow the pump motor to cool at least 30 minutes before resuming operation. Pump overheating can be caused by:

- Solidified shortening in the pan or filter lines, or
- Attempting to filter unheated oil (cold oil is more viscous, overloading the pump motor and causing it to overheat).

If the motor runs but the pump does not return oil, there is a blockage in the pump. Incorrectly sized or installed paper/pads will allow food particles and sediment to pass through the filter pan and into the pump. When sediment enters the pump, the gears bind, causing the motor to overload, again tripping the thermal overload. Shortening that has solidified in the pump will also cause it to seize, with the same result.

A pump seized by debris or hard shortening can usually be freed by manually moving the gears with a screwdriver or other instrument.

Disconnect power to the filter system, remove the input plumbing from the pump, and use a screwdriver to manually turn the gears.

- Turning the pump gears in reverse will release a hard particle.
- Turning the pump gears forward will push softer objects and solid shortening through the pump and allow free movement of the gears.

Incorrectly sized or installed paper/pads will also allow food particles and sediment to pass through and clog the suction tube on the bottom of the filter pan. Particles large enough to block the suction tube may indicate that the crumb tray is not being used. Pan blockage can also occur if shortening is left in the pan and allowed to solidify. Blockage removal can be accomplished by forcing the item out with an auger or drain snake. Compressed air or other pressurized gases should not be used to force out the blockage.

### 1.9.2 Replacing the Filter Motor, Filter Pump, and Related Components

1. Remove the filter pan and lid from the unit. Drain the frypots into a Shortening Disposal Unit (SDU) or other appropriate metal container.

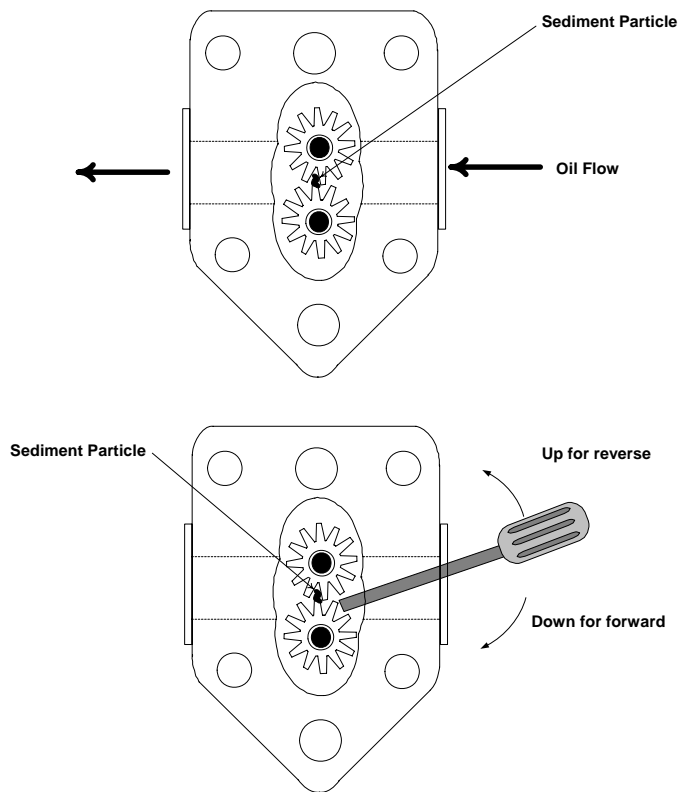

**⚠ DANGER**

**DO NOT drain more than one full frypot or two split frypots into the SDU at one time.**

2. Disconnect the fryer from the electrical power supply and reposition it to gain access to both the front and rear.
3. Disconnect the two flexlines running to the oil-return manifold at the rear of the fryer as well as the pump suction flexline at the end of the filter pan connection (see photo below).

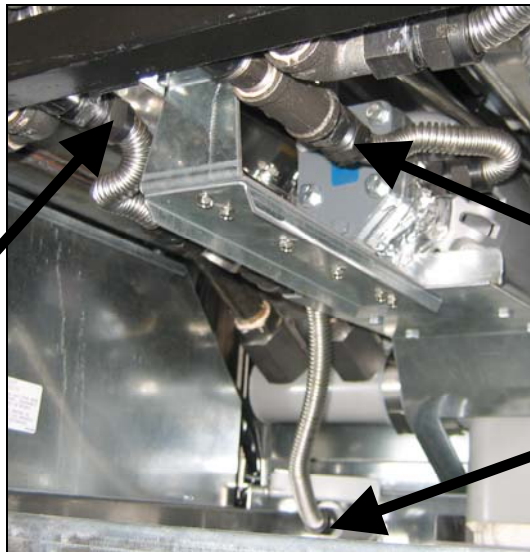

Disconnect flexlines indicated by the arrows.

4. Loosen the nut and bolt that secures the bridge to the oil-return manifold.
5. Remove the cover plate from the front of the motor and disconnect the motor wires.
6. Unplug the pump motor assembly 6-pin connector C-2 and, using a pin pusher, disconnect the vent vacuum-breaker solenoid (pins 2 and 5) that is attached to the oil return manifold.
7. Remove the two nuts and bolts that secure the front of the bridge to the cross brace and carefully slide the bridge rearward off the cross brace until its front end can be lowered to the floor. Undo the single nut holding it in place in back. Be careful not to let the rear of the bridge slip off the manifold at this point.
8. Get a good grip on the bridge, carefully pull it forward off the oil-return manifold, and lower the entire assembly to the floor. Once on the floor, pull the assembly out the front of the fryer.
9. When required service has been completed, reverse steps 6-12 to reinstall the bridge. **NOTE:** The black motor wires go on the top terminal, the white on the bottom. The pump solenoid valve wires go in positions 1 and 4 of the 6-pin connector C-2; the vent vacuum-breaker solenoid valve wires go in positions 2 and 5; the red/black heater tape wires go into position 3 and the violet/white wires go into position 6 (see illustration on the following page).

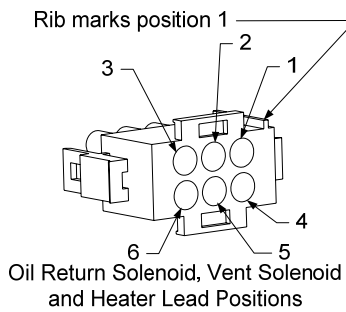

10. Reconnect the unit to the electrical power supply, and verify that the pump is functioning correctly (i.e., when a filter handle is placed in the ON position, the motor should start and there should be strong suction at the intake fitting and outflow at the rear flush port.)
11. When proper operation has been verified, reinstall the back panels and the filter pan and lid.
12. Reposition the fryer under the exhaust hood and reconnect it to the electrical power supply to return the fryer to service.

### 1.9.3 Replacing the Filter Transformer or Filter Relay

Disconnect the fryer from the electrical power supply. Remove the left controller from the fryer to expose the interior of the left component box. The filter transformer and relay are located as shown in the illustration below. **NOTE:** The right component box is identical to the left except that the filter transformer and relay are not present. The components are held on by threaded pin studs so that only removal of the nut is required to replace the component.

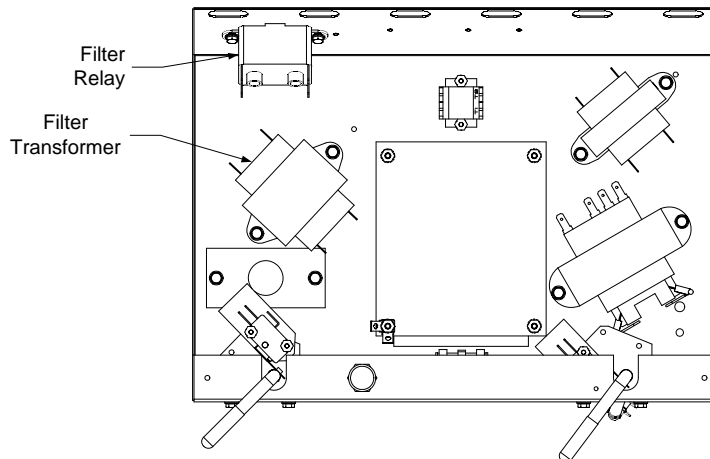

Dual-vat configuration illustrated. In full-vat units, left filter handle is not present.

### 1.10 Basket Lift Service Procedures

RE Series electric fryers may be equipped with automatic basket lifts. Basket lifts always come in pairs, although each operates independently.

A **modular basket lift** (illustrated on the following page) is a self-contained sub-assembly consisting of a pair of toothed rods which support removable basket lift arms, a pair of reversible-drive gear motors, and four microswitches. The gear motors engage the teeth of the rods, moving them up or down depending upon the motors' direction of rotation. The microswitches at the upper and lower limits of movement stop the motors when the basket is in the full up or full down position.

Timing circuitry in the controller initiates and stops basket lift operation depending upon the variables programmed by the operator. When the product button is pressed, the timing circuitry activates a coil in the basket lift relay to supply power to the lower microswitch. The microswitches stop the motor at the lift's upper and lower travel limits and reverse the direction of current flow thus reversing the motor direction.

When the product button is pushed on the computer/controller, current flows through a coil in the basket lift relay, causing the lower circuit to be activated. The basket lift lowers, closing the normally open upper-micro-switch. When the downward-moving rod opens the lower normally closed microswitch, the power to the motor ceases to flow. When the computer/controller times out, the current to the relay coil is cut, allowing the upper circuit to be activated. The basket lift then raises and re-closes the lower microswitch. When the basket lift rod clears the upper microswitch, the microswitch reopens, power to the circuit is cut, and the motor stops. Pushing the product button restarts the cycle.

Problems with the basket lift can be grouped into three categories:

- Binding/jamming problems
- Motor and gear problems
- Electronic problems

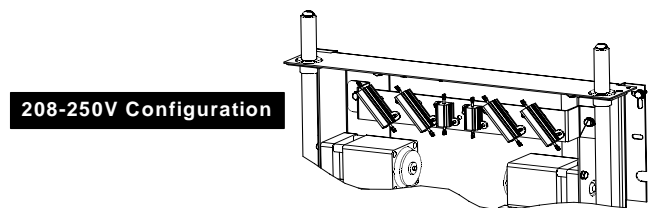
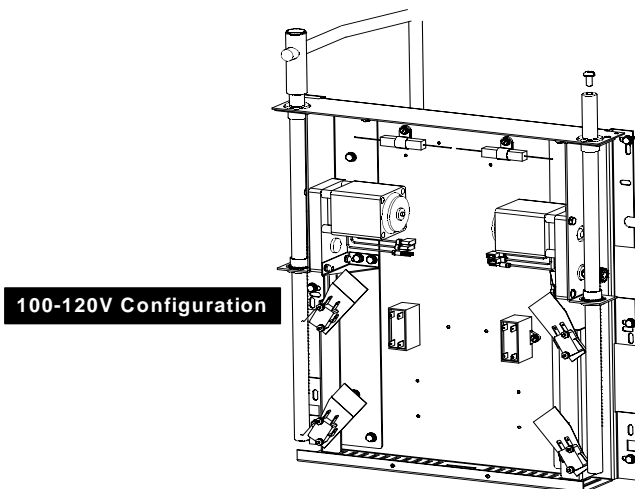

## **BINDING/JAMMING PROBLEMS**

Noisy, jerky or erratic movement of the lifts is usually due to lack of lubrication of the rods and their bushings. Apply a light coat of Lubriplate<sup>®</sup> or similar lightweight white grease to the rod and bushings to correct the problem.

With the modular basket lift, another possible cause of binding is improper positioning of the motor, which prevents the gear from correctly engaging the teeth in the rod. To correct the problem, loosen the screws that hold the motor in place and move it forward or backward until the rod has just enough slack to be rotated slightly.

## MOTOR AND GEAR PROBLEMS

With the modular basket lift, the most likely problem to be encountered in this category is erratic motion of the lift due to a worn drive gear. Failure to keep the lift rod and bushings properly lubricated will cause unnecessary wear of the gear. The problem is corrected by replacing the worn gear.

If the lift cycles correctly but fails to remain in the up position (i.e., goes up, but then slowly settles back down into the frypot), the problem is a failed motor brake. A failed motor brake cannot be repaired and requires replacement of the motor itself.

If power is reaching the motor but the motor fails to run, the motor is burned out and must be replaced.

## ELECTRONIC PROBLEMS

Within this category are problems associated with the relays, microswitches, capacitors, resistors, interface board, wiring, and controls. The most common problem in this category is a lift that continuously travels up and down. This is usually caused by a microswitch that is out of adjustment. Troubleshooting the electronics of a modular basket lift is simply a process of verifying current flow through the individual components up to and including the motor. Using a multimeter set to the 250 VAC range, check the connections on both sides of the component for the presence of the applied line voltage. The schematic below and the wiring diagram on page 1-16 can identify the components and wiring connection points.

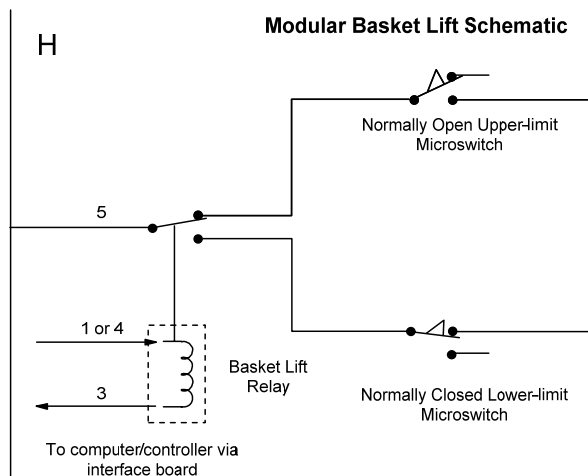

## 1.11 Interface Board Diagnostic Chart

The following diagram and charts provide ten quick system checks that can be performed using only a multimeter.

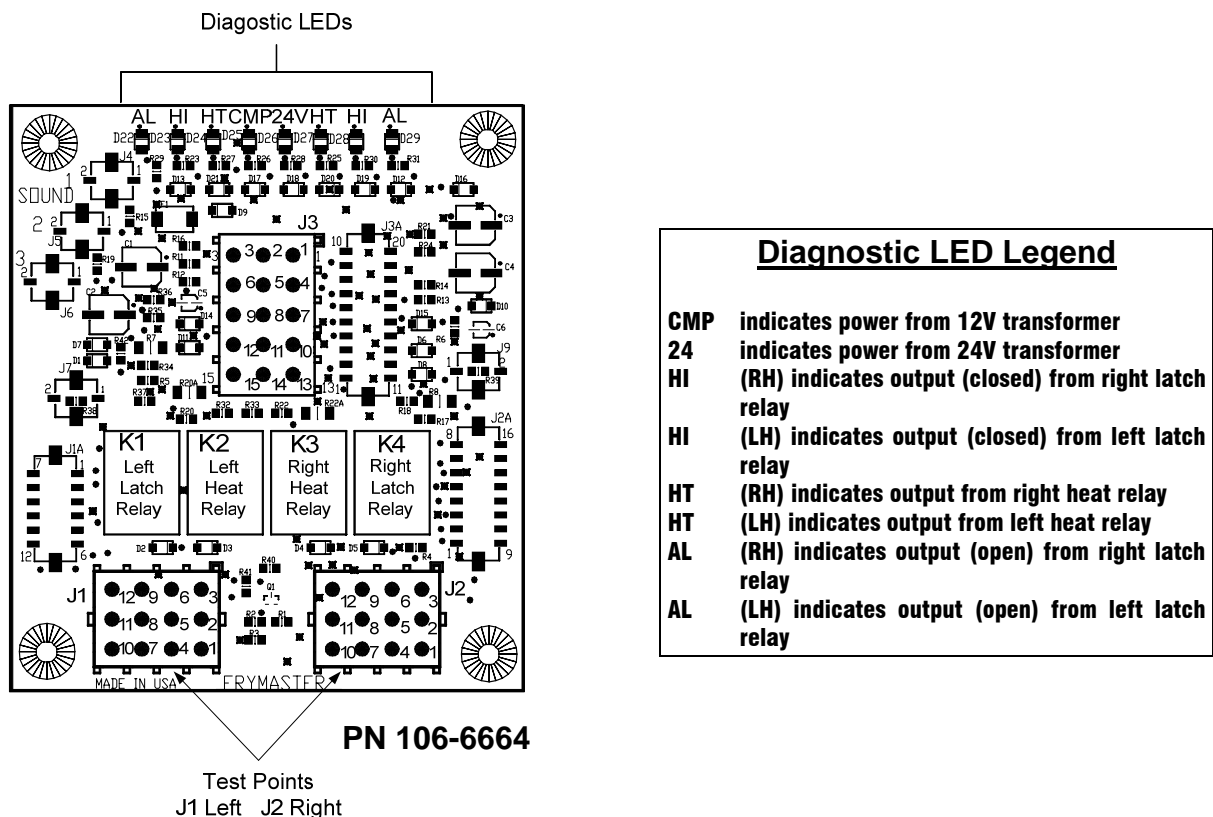

**NOTE** – When testing the test points on J1 and J2 test use the illustration above disregarding any silk-screened numbers on the board depicting the location of Pin 1. Pin 1 is located in the bottom right corner of Both J1 and J2. These test points are **ONLY** for RE Series boards with J1 and J2 plugs on the front of the board.

Meter Setting	Test	Pin	Pin	Results
12 VAC Power	50 VAC Scale	3 of J2	1 of J2	12-16 VAC
24 VAC Power	50 VAC Scale	2 of J2	Chassis	24-30 VAC
*Probe Resistance (RH)	R X 1000 OHMS	11 of J2	10 of J2	See Chart
*Probe Resistance (LH)	R X 1000 OHMS	1 of J1	2 of J1	See Chart
High-Limit Continuity (RH)	R X 1 OHMS	9 of J2	6 of J2	0 - OHMS
High-Limit Continuity (LH)	R X 1 OHMS	6 of J1	9 of J1	0 - OHMS
Latch Contactor Coil (RH)	R X 1 OHMS	8 of J2	Chassis	3-10 OHMS
Latch Contactor Coil (LH)	R X 1 OHMS	5 of J1	Chassis	3-10 OHMS
Heat Contactor Coil (RH)	R X 1 OHMS	7 of J2	Chassis	11-15 OHMS
Heat Contactor Coil (LH)	R X 1 OHMS	4 of J1	Chassis	11-15 OHMS

\* Disconnect 15-Pin harness from the computer/controller before testing the probe circuit.

## 1.12 Probe Resistance Chart

<h3 style="text-align: center;">Probe Resistance Chart</h3> <p style="text-align: center;"><i>For use with fryers manufactured with Minco Thermistor probes only.</i></p>																	
F	OHMS	C	F	OHMS	C	F	OHMS	C	F	OHMS	C	F	OHMS	C			
60	1059	16	130	1204	54	200	1350	93	270	1493	132	340	1634	171			
65	1070	18	135	1216	57	205	1361	96	275	1503	135	345	1644	174			
70	1080	21	140	1226	60	210	1371	99	280	1514	138	350	1654	177			
75	1091	24	145	1237	63	215	1381	102	285	1524	141	355	1664	179			
80	1101	27	150	1247	66	220	1391	104	290	1534	143	360	1674	182			
85	1112	29	155	1258	68	225	1402	107	295	1544	146	365	1684	185			
90	1122	32	160	1268	71	230	1412	110	300	1554	149	370	1694	188			
95	1133	35	165	1278	74	235	1422	113	305	1564	152	375	1704	191			
100	1143	38	170	1289	77	240	1432	116	310	1574	154	380	1714	193			
105	1154	41	175	1299	79	245	1442	118	315	1584	157	385	1724	196			
110	1164	43	180	1309	82	250	1453	121	320	1594	160	390	1734	199			
115	1174	46	185	1320	85	255	1463	124	325	1604	163	395	1744	202			
120	1185	49	190	1330	88	260	1473	127	330	1614	166	400	1754	204			
125	1195	52	195	1340	91	265	1483	129	335	1624	168	405	1764	207			

## 1.13 Wiring Diagrams

### 1.13.1.1 Modular Basket Lift Wiring Diagram 208-250V

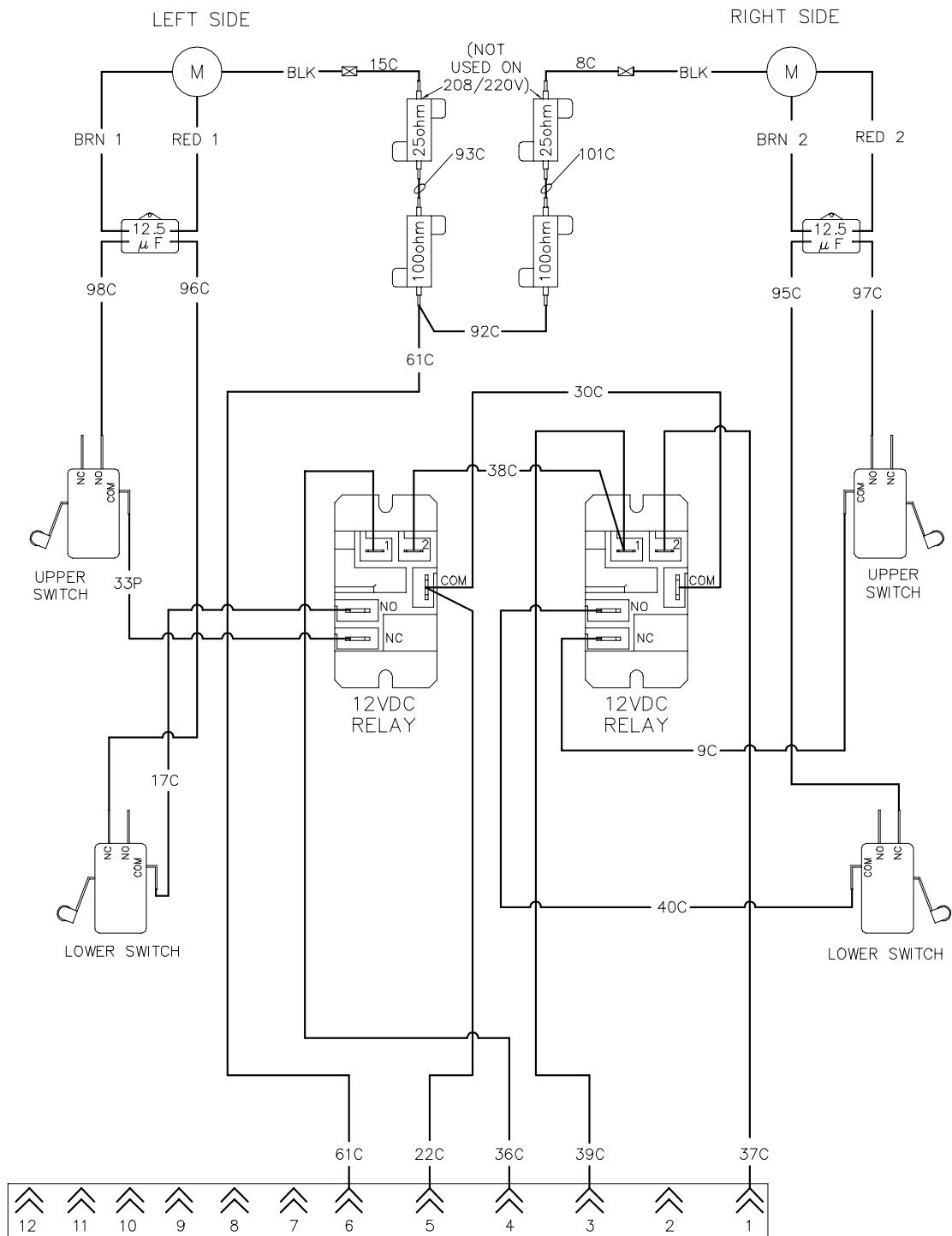

REFERENCES TO LEFT & RIGHT ARE  
FROM THE REAR OF THE FRYER

8050888D

### 1.13.1.2 Modular Basket Lift Wiring Diagram 100-120V

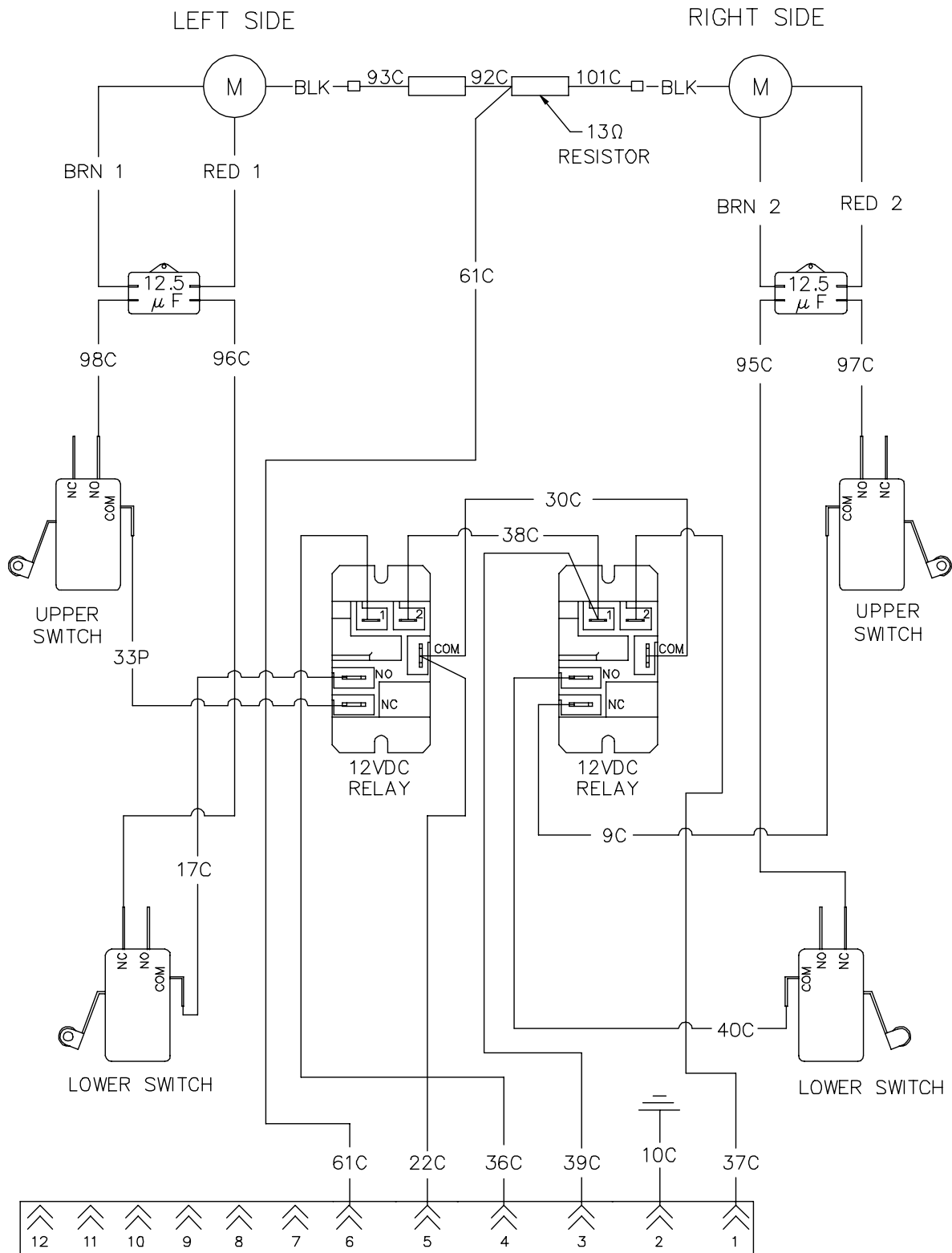

REFERENCES TO LEFT & RIGHT ARE FROM THE REAR OF THE FRYER

8050555E



### 1.13.2.2 Component Wiring- Fryer and Half

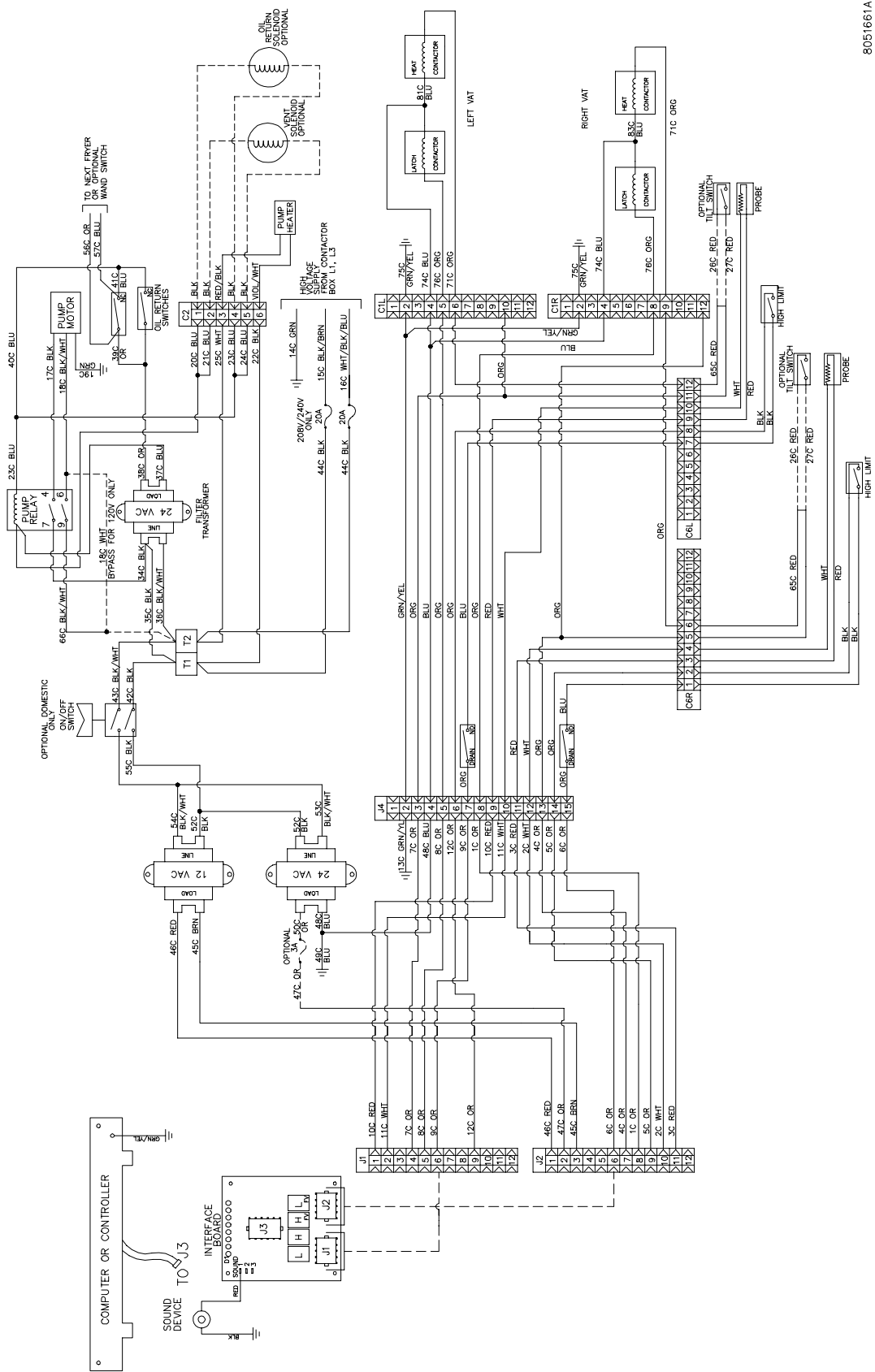

8051661A

### 1.13.3 Tilt Switch Wiring

#### Standard

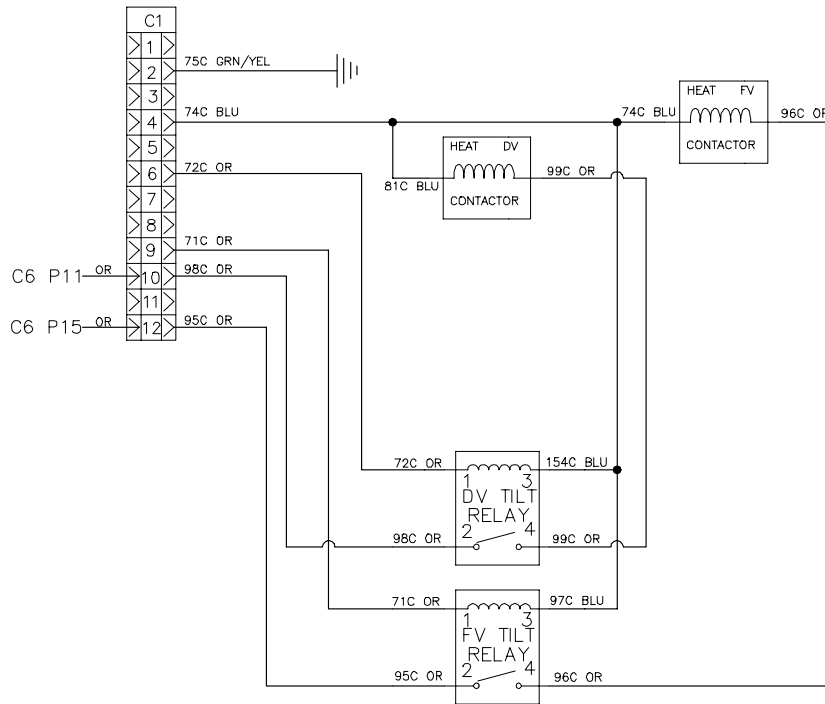

8051612B

#### Fryer and half

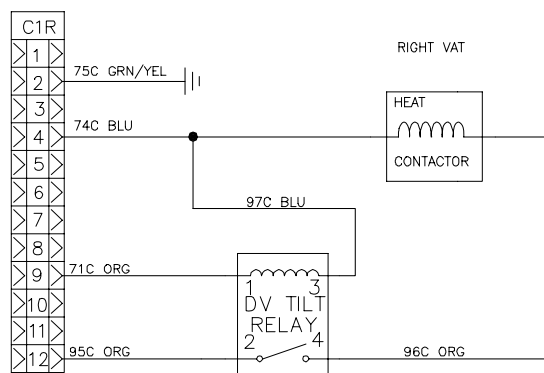
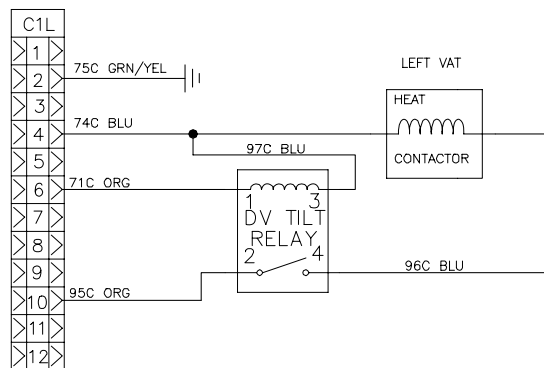

8051662A



### 1.13.5 Fast Ready Computer Wiring

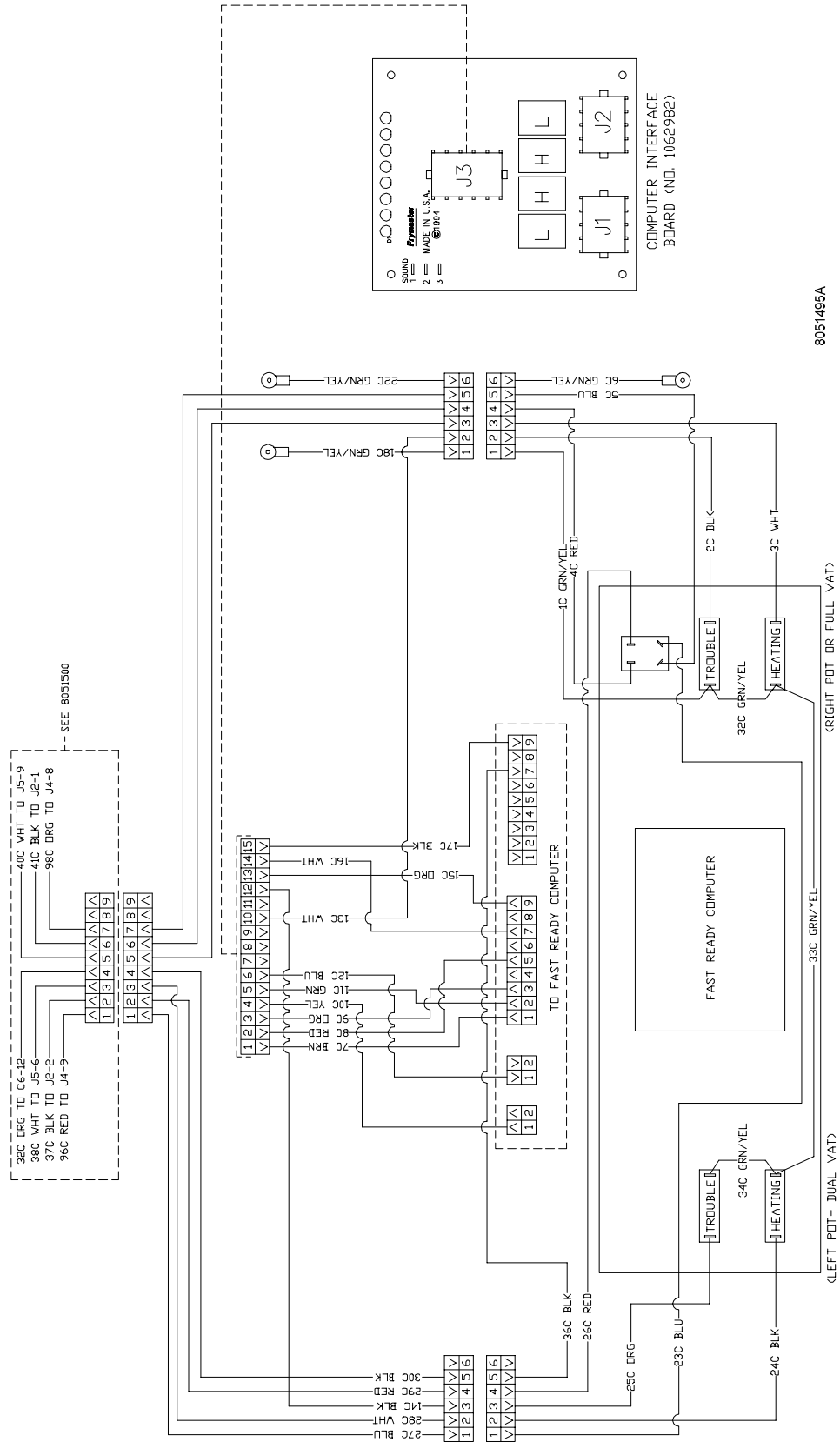

# 1.13.6 Computer Harness - Fast Ready

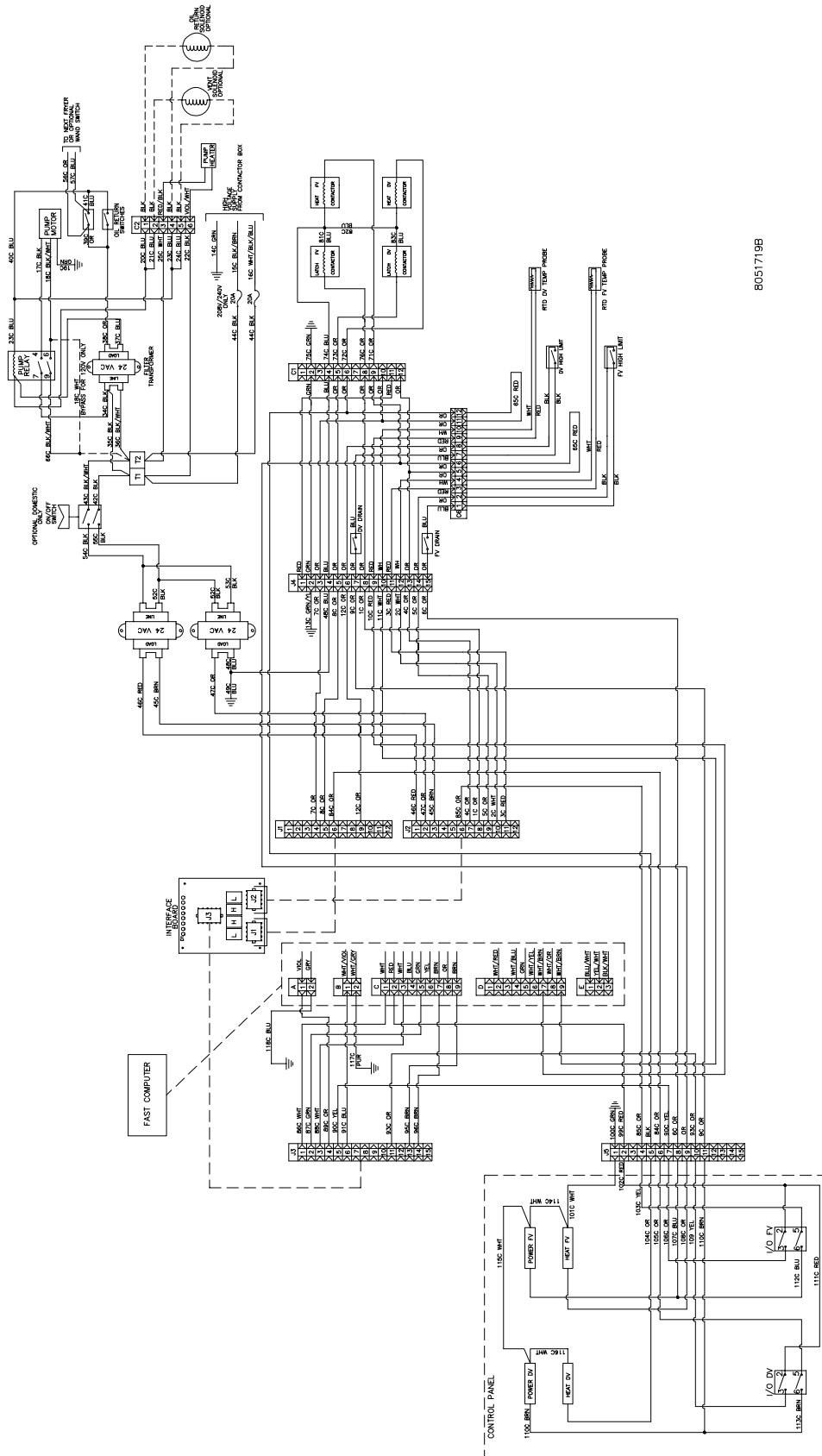

# 1.13.7 Control Wiring - Fast Ready

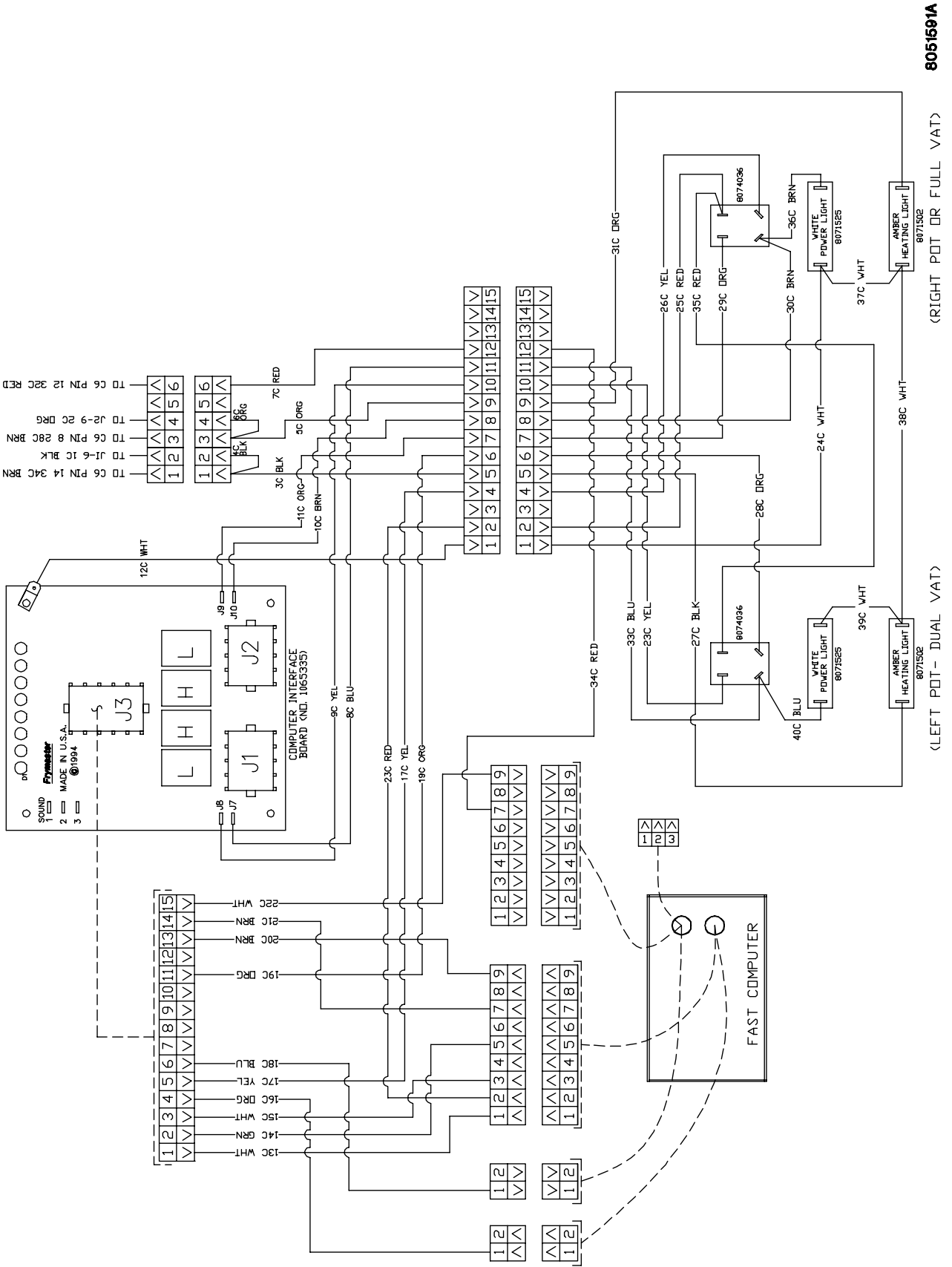

# 1.13.8 Contactor – DELTA Configuration

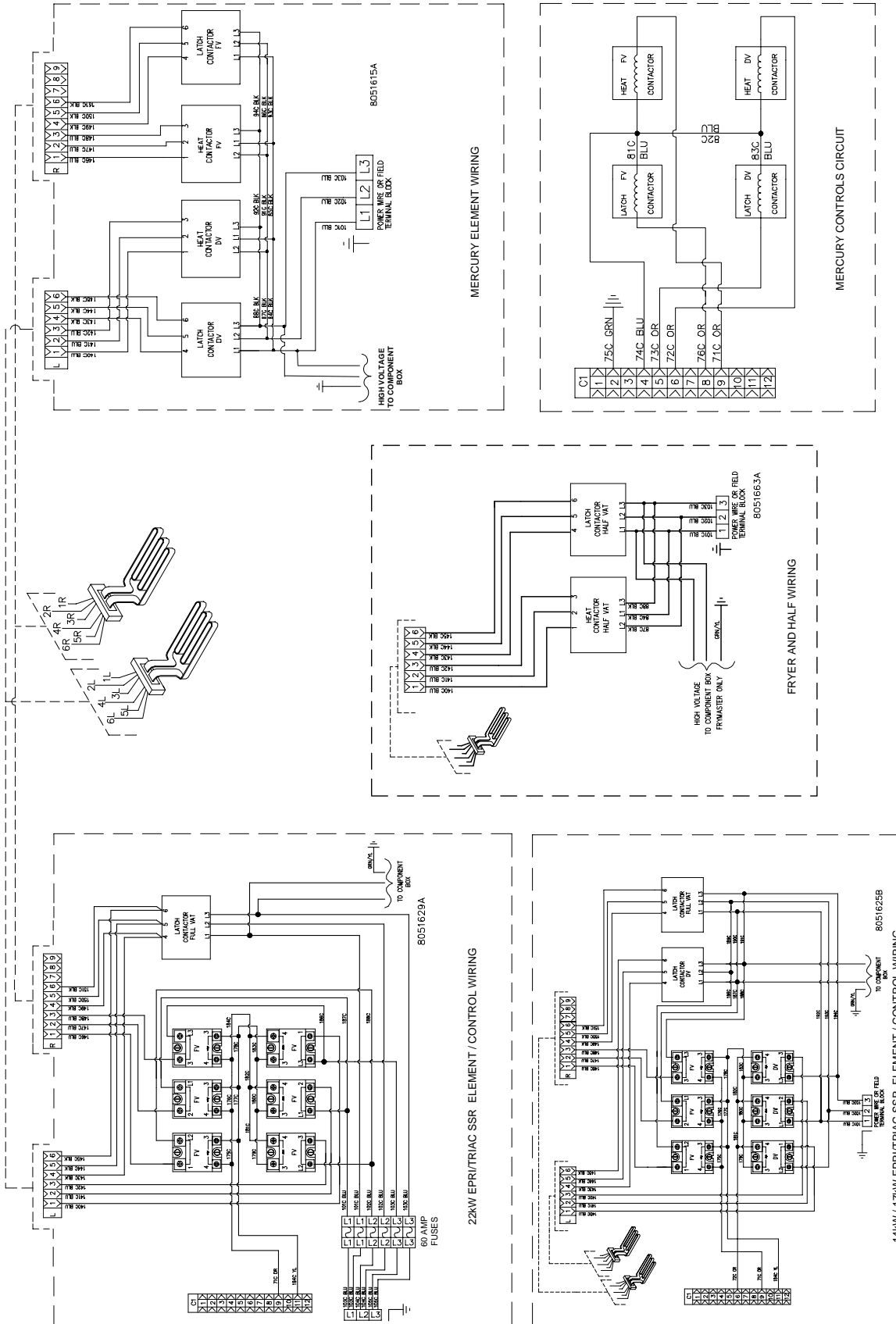

### 1.13.8 Contactor – DELTA Configuration cont.

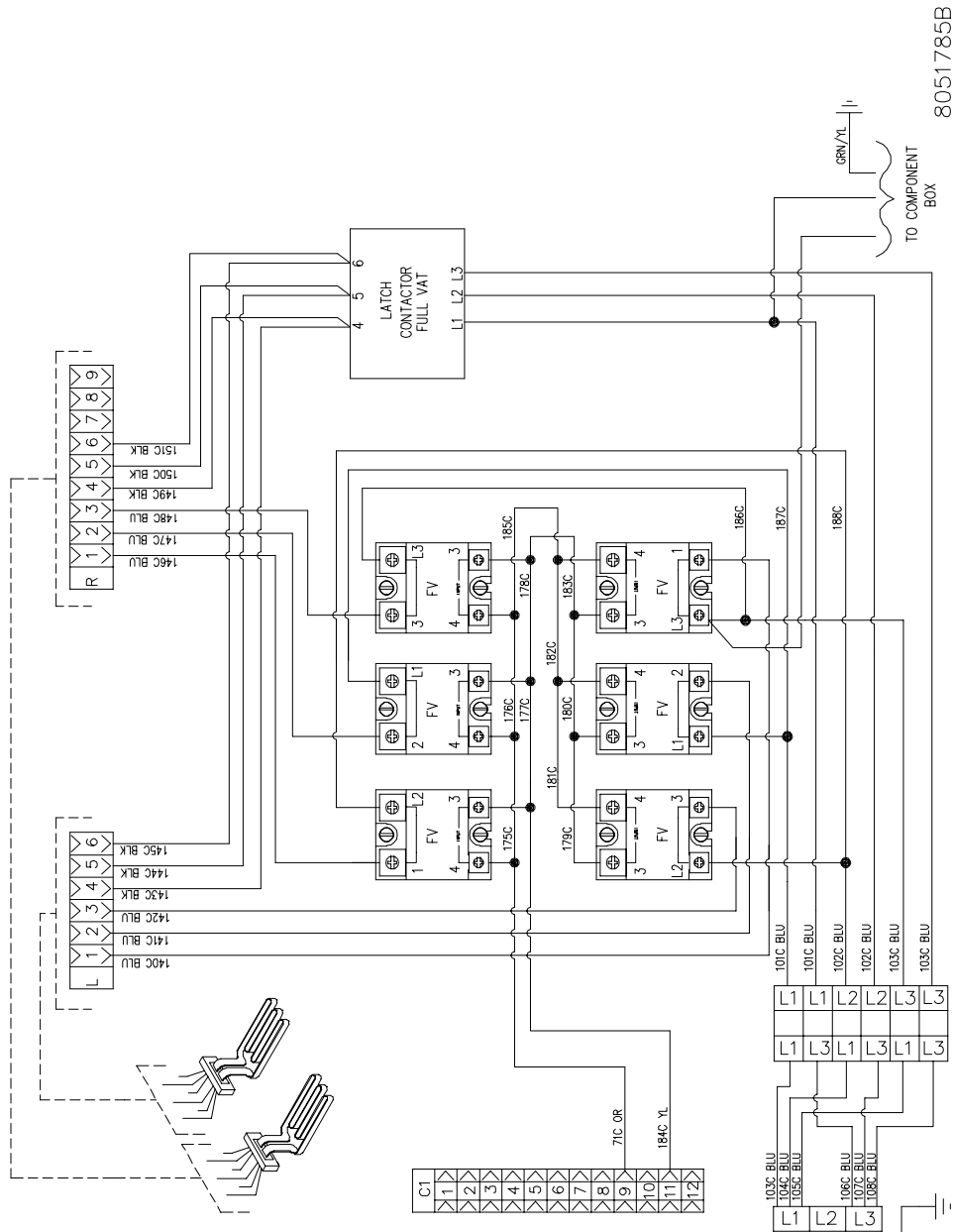

22kW Single Phase SSR Wiring

8051785B

# 1.13.9 Contactor Box - WYE Configuration Export

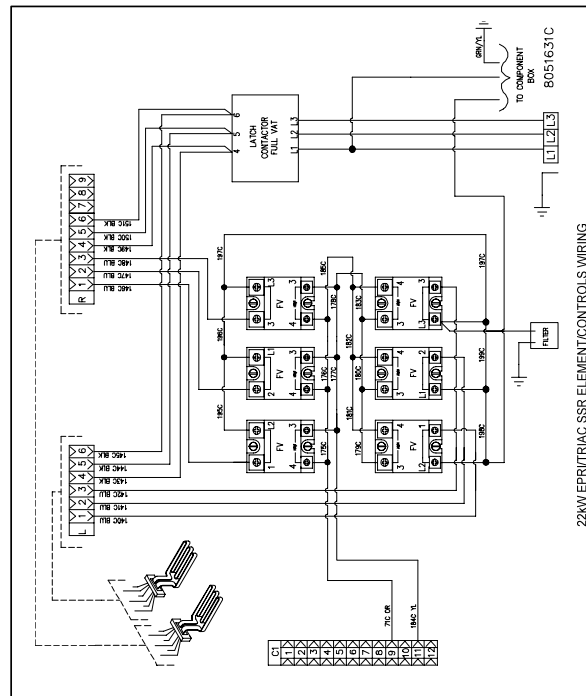
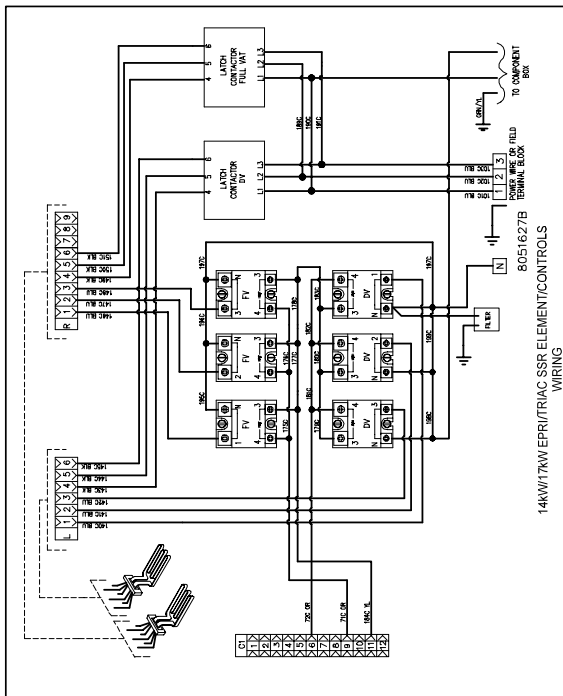
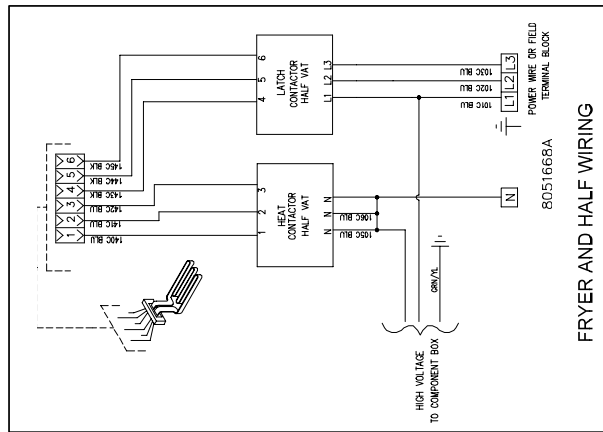
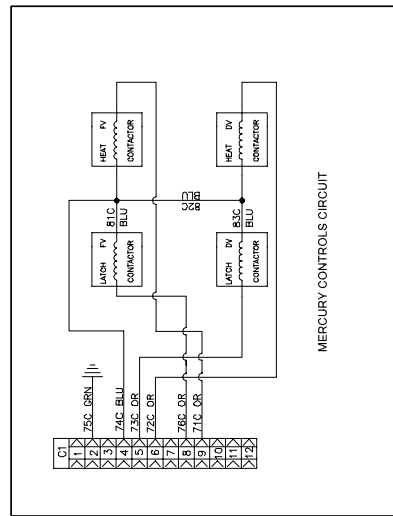
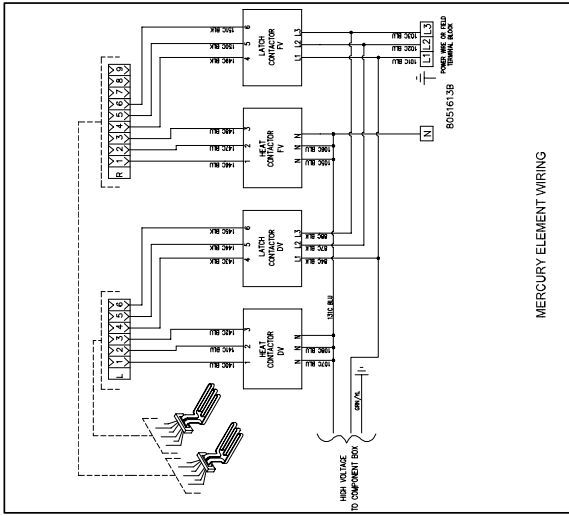

### 1.13.10 Terminal Block Wiring

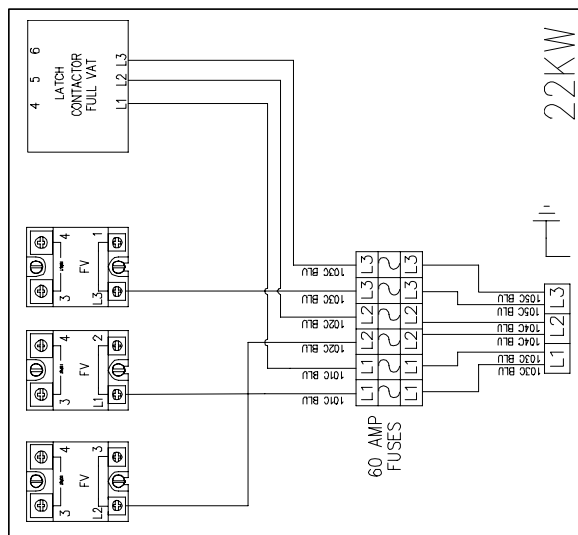
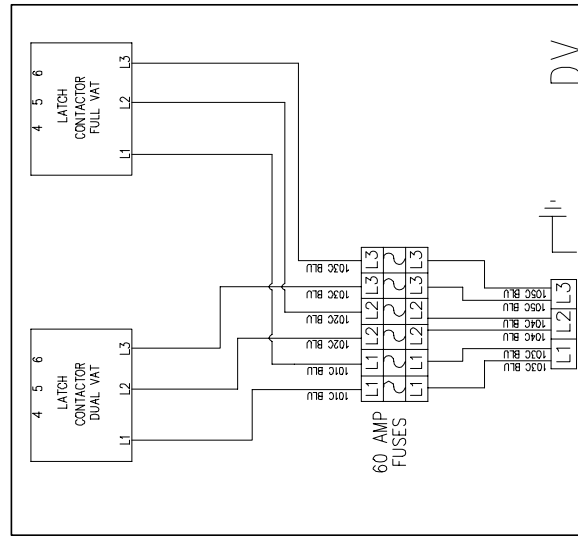
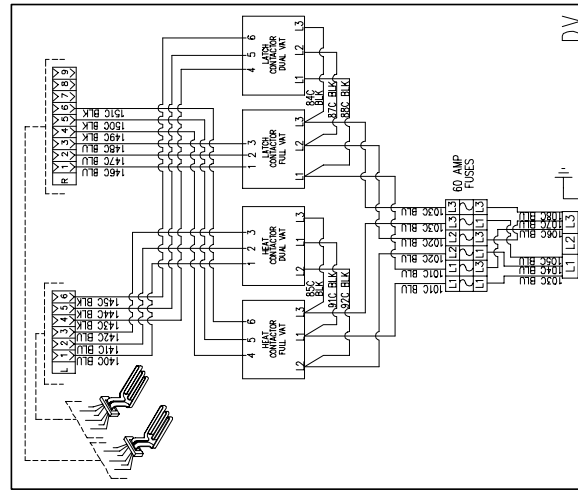
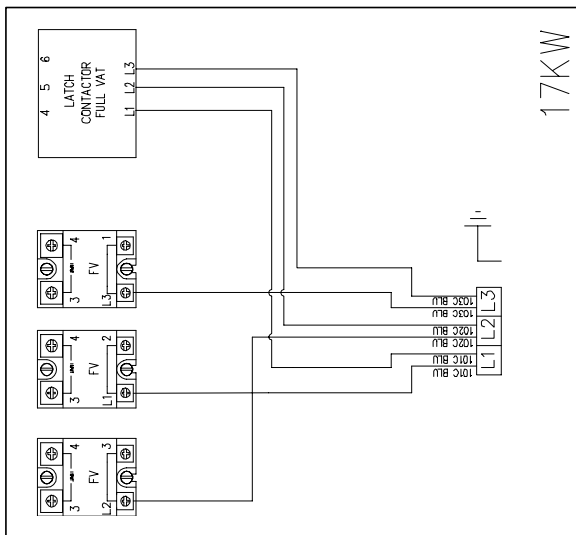
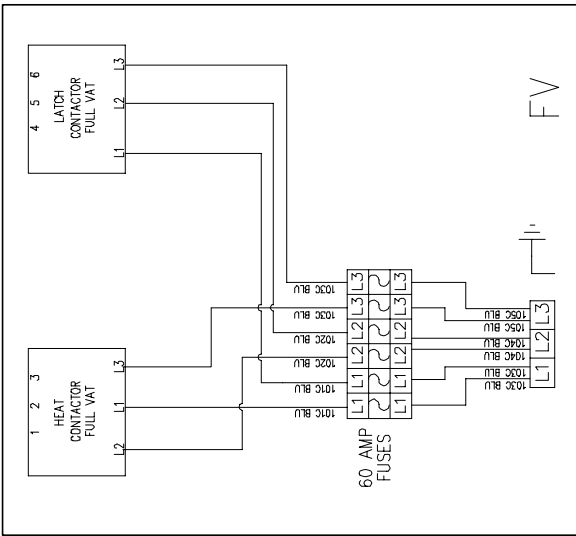
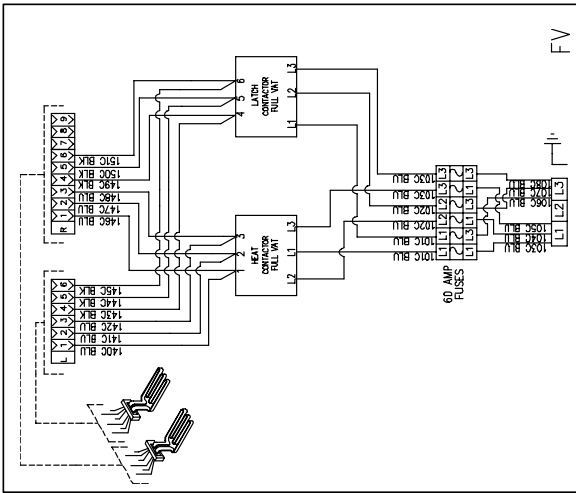

8051632C  
SINGLE PHASE TERMINAL BLOCK WIRING DIAGRAMS

8051634B  
22kW TERMINAL BLOCK WIRING DIAGRAMS

8051633A  
EPR/TRIAC TERMINAL BLOCK WIRING DIAGRAMS

### 1.13.11 Oil Disposal Wiring

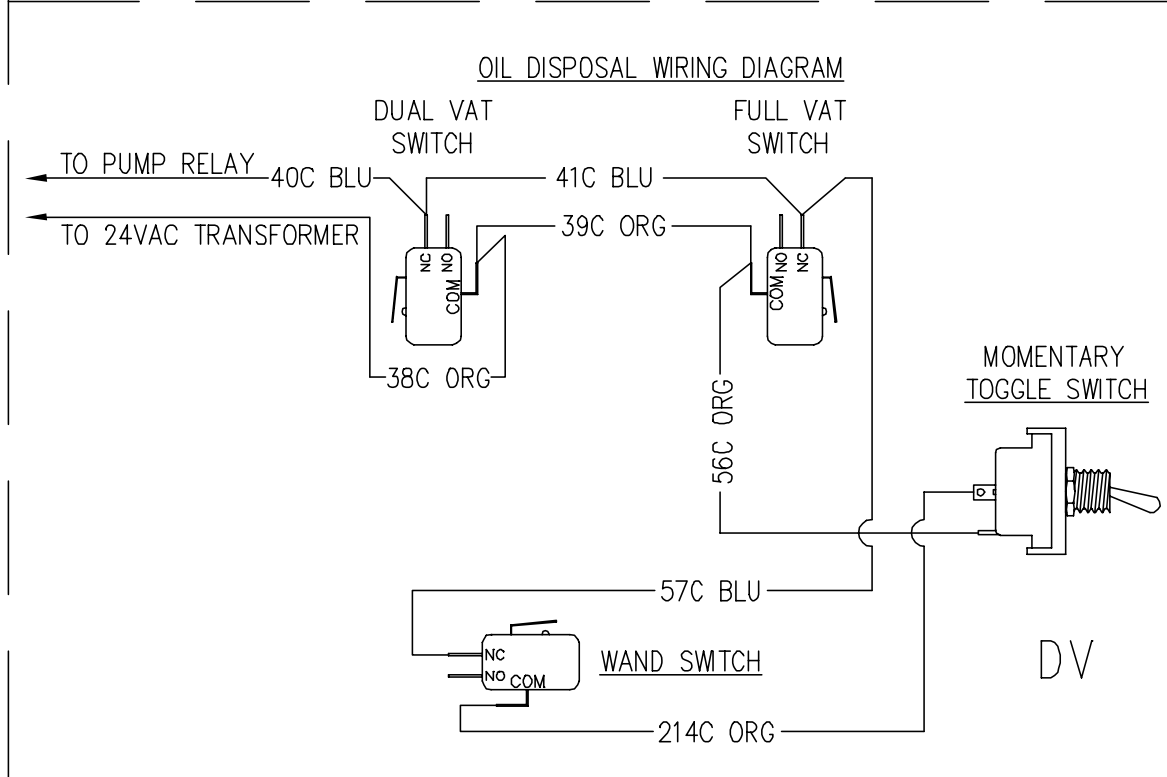
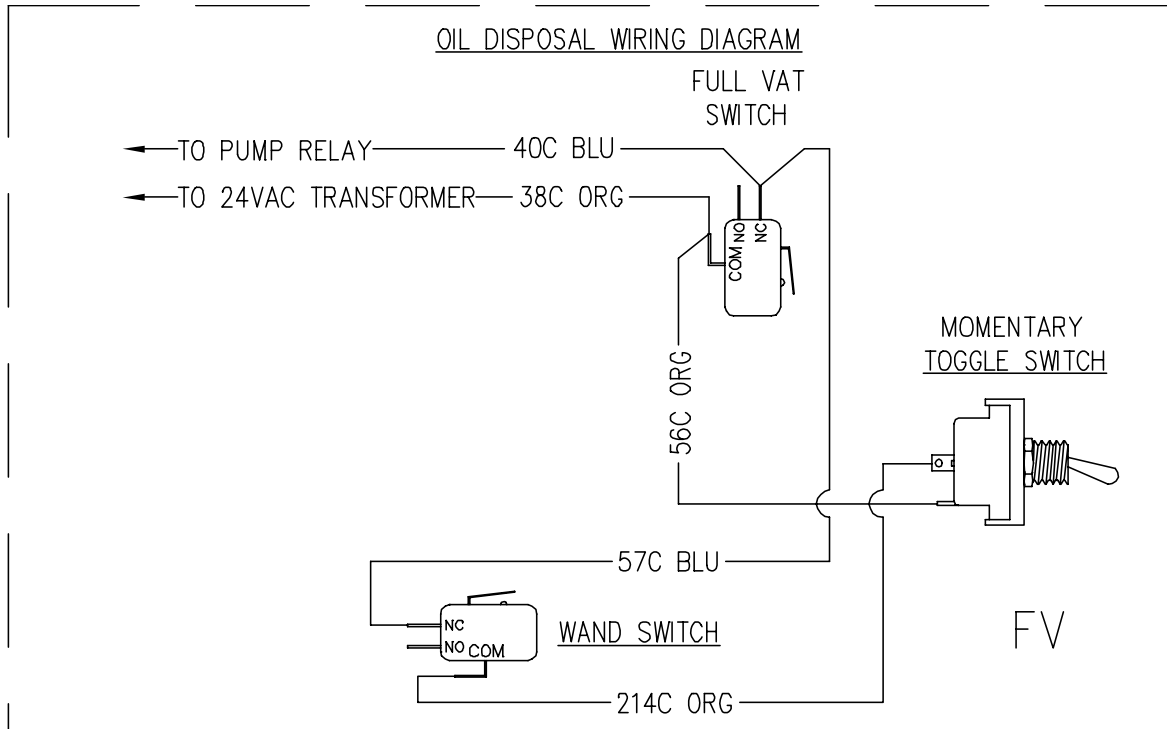

8051653A

### 1.13.12 Simplified RE14/17/22 Series – Full Vat Wiring

## ELECTRIC RE14/17/22 SERIES - FULL-VAT

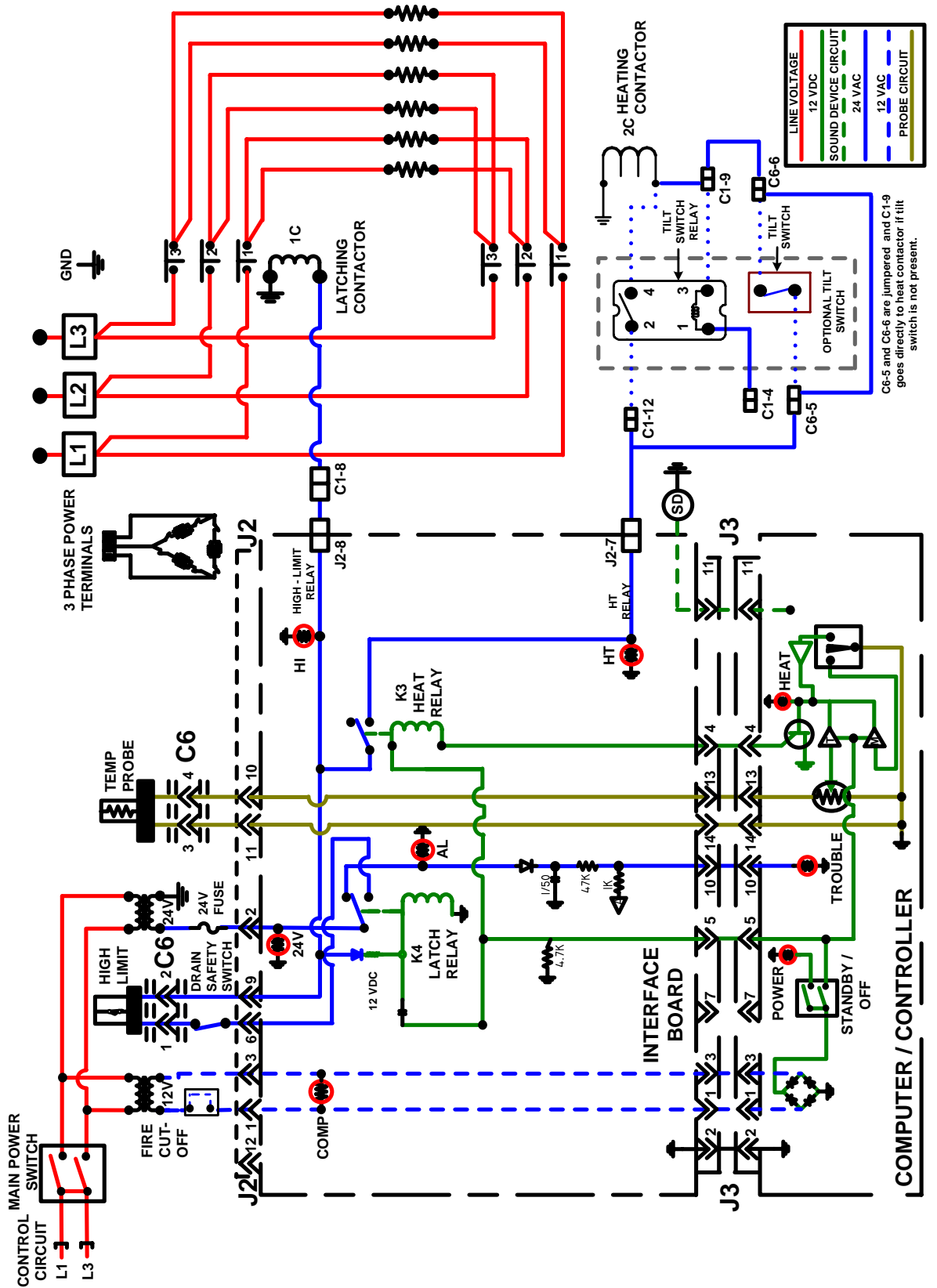

### 1.13.13 Simplified RE14/17/22 Series – Dual Vat Wiring

## ELECTRIC RE14/17/22 SERIES - DUAL-VAT

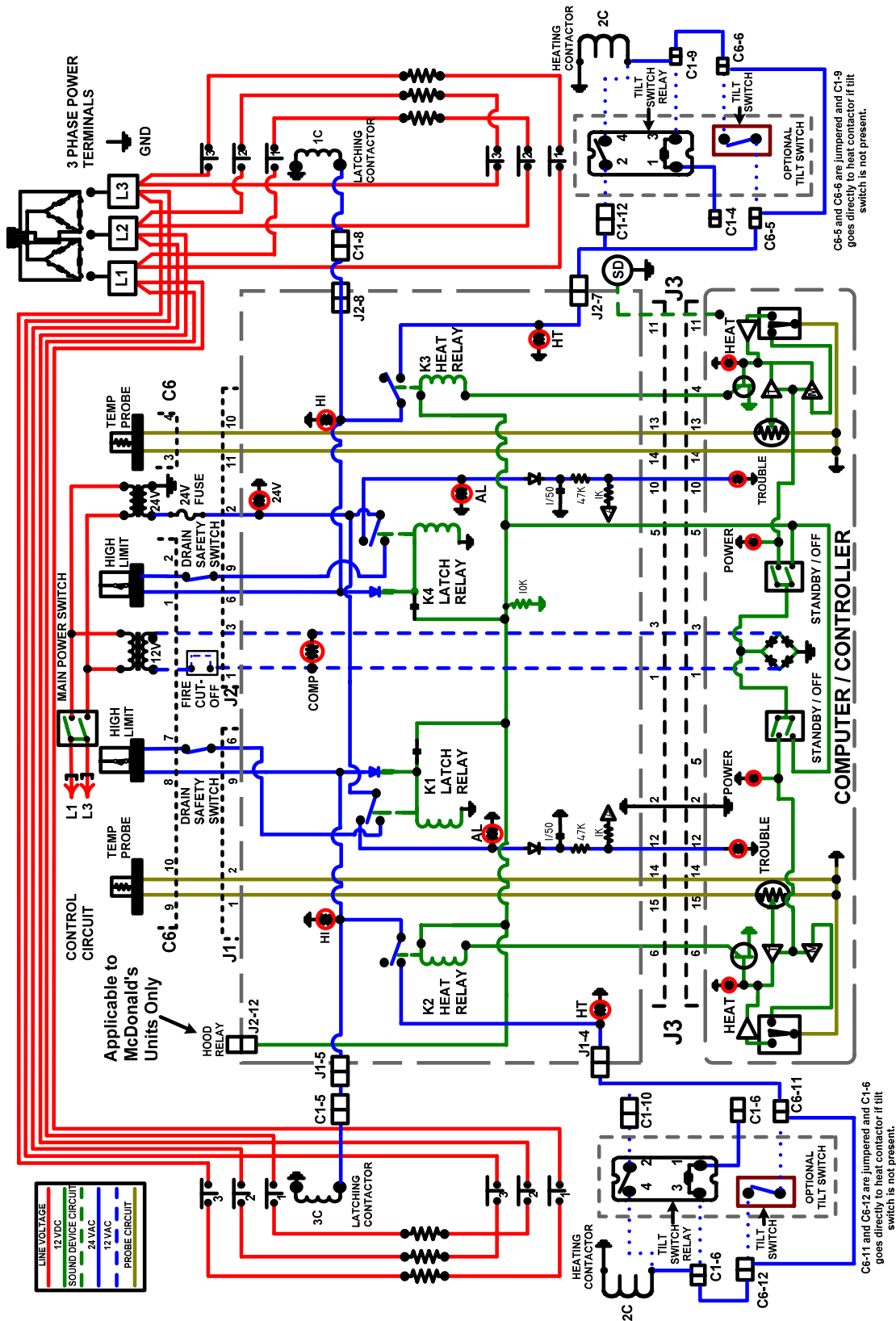

### 1.13.14 Simplified RE14/17/22 Series – Full Vat Wiring (EXPORT) WYE

## ELECTRIC RE14/17/22 SERIES - FULL-VAT EXPORT WYE

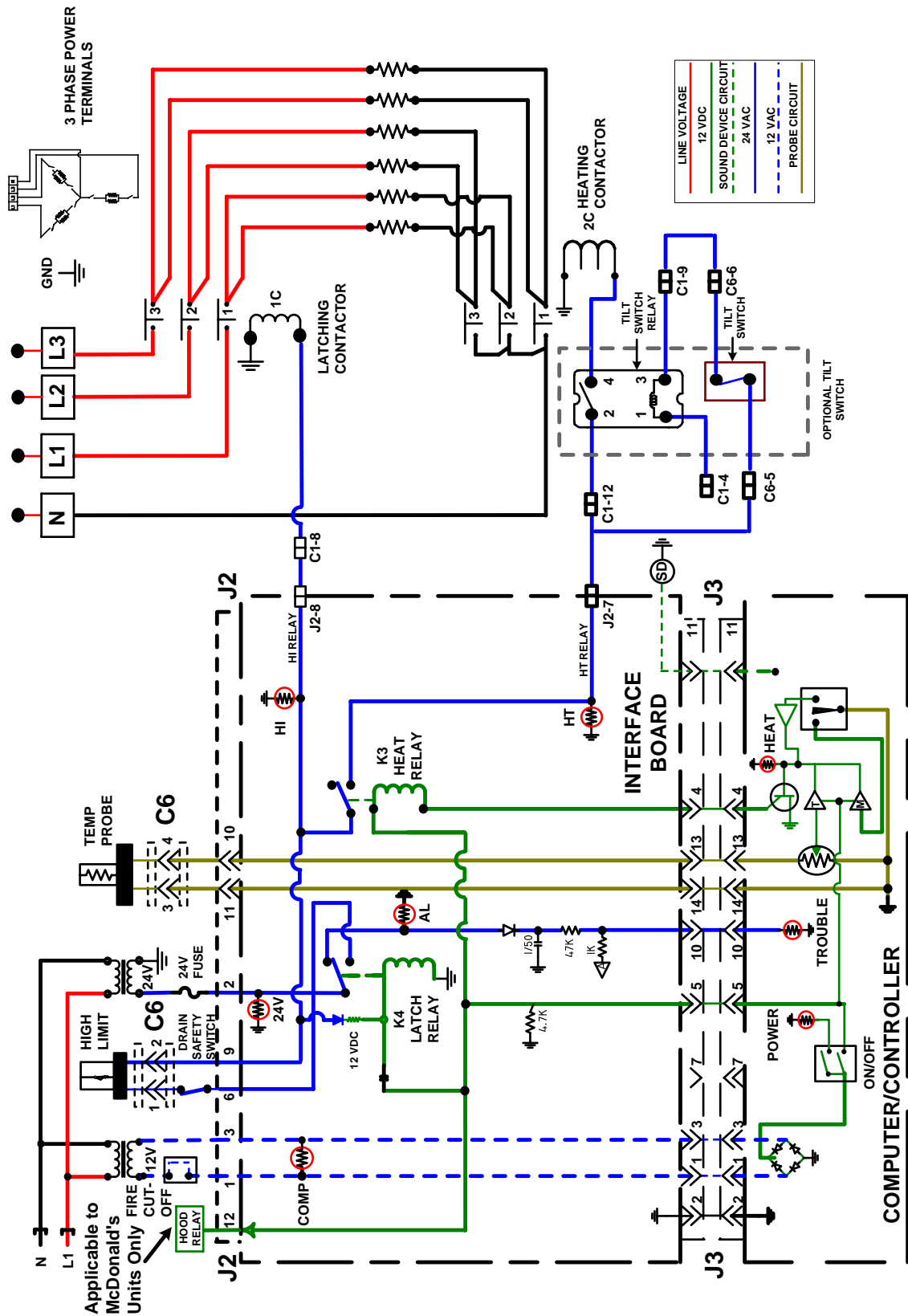

### 1.13.15 Simplified RE14/17/22 Series – Dual Vat Wiring (EXPORT) WYE

## ELECTRIC RE14/17/22 SERIES - DUAL-VAT EXPORT WYE

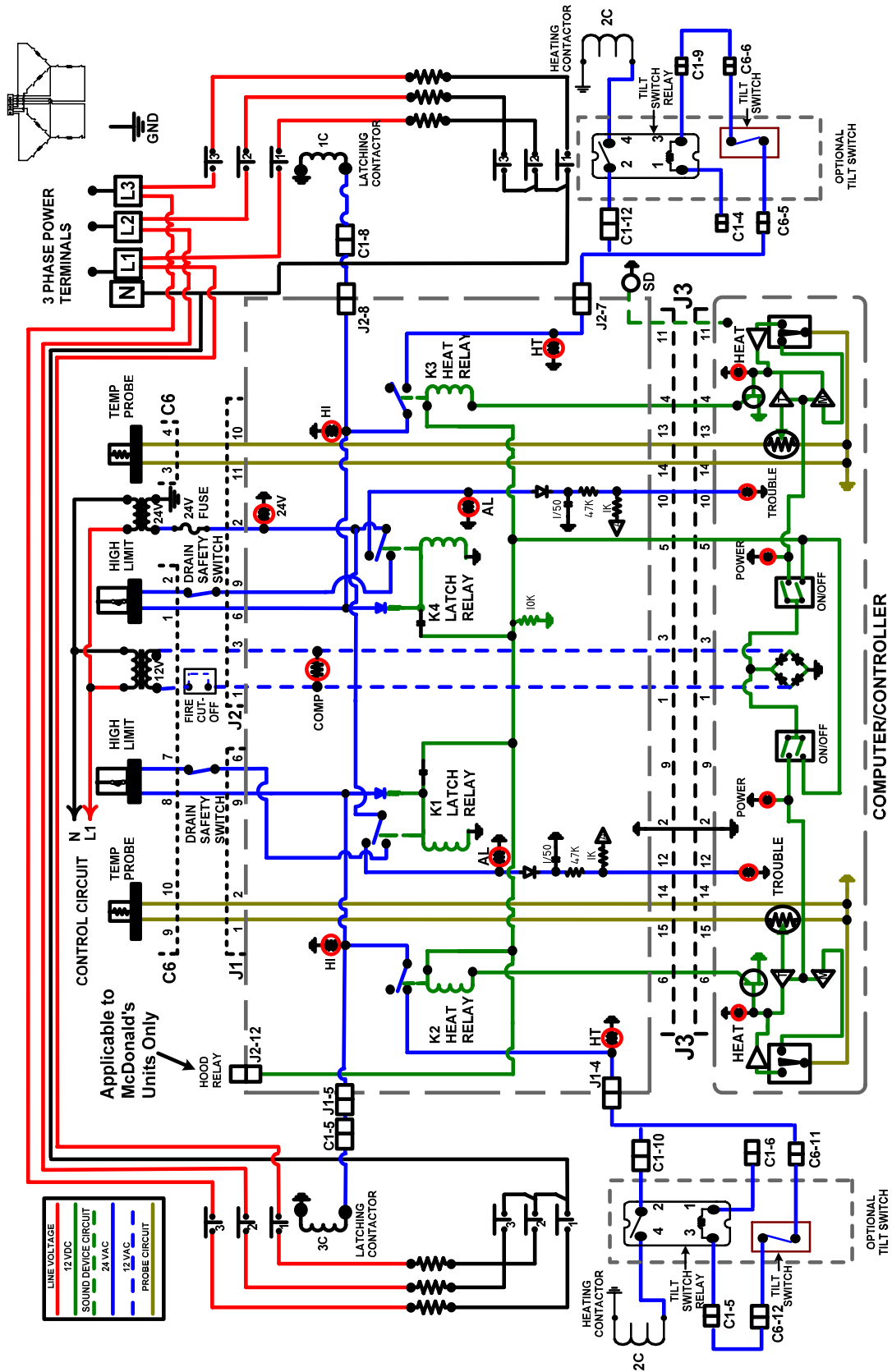

# 1.13.16 Simplified RE14/17/22 Series – Full Vat Wiring EPRI

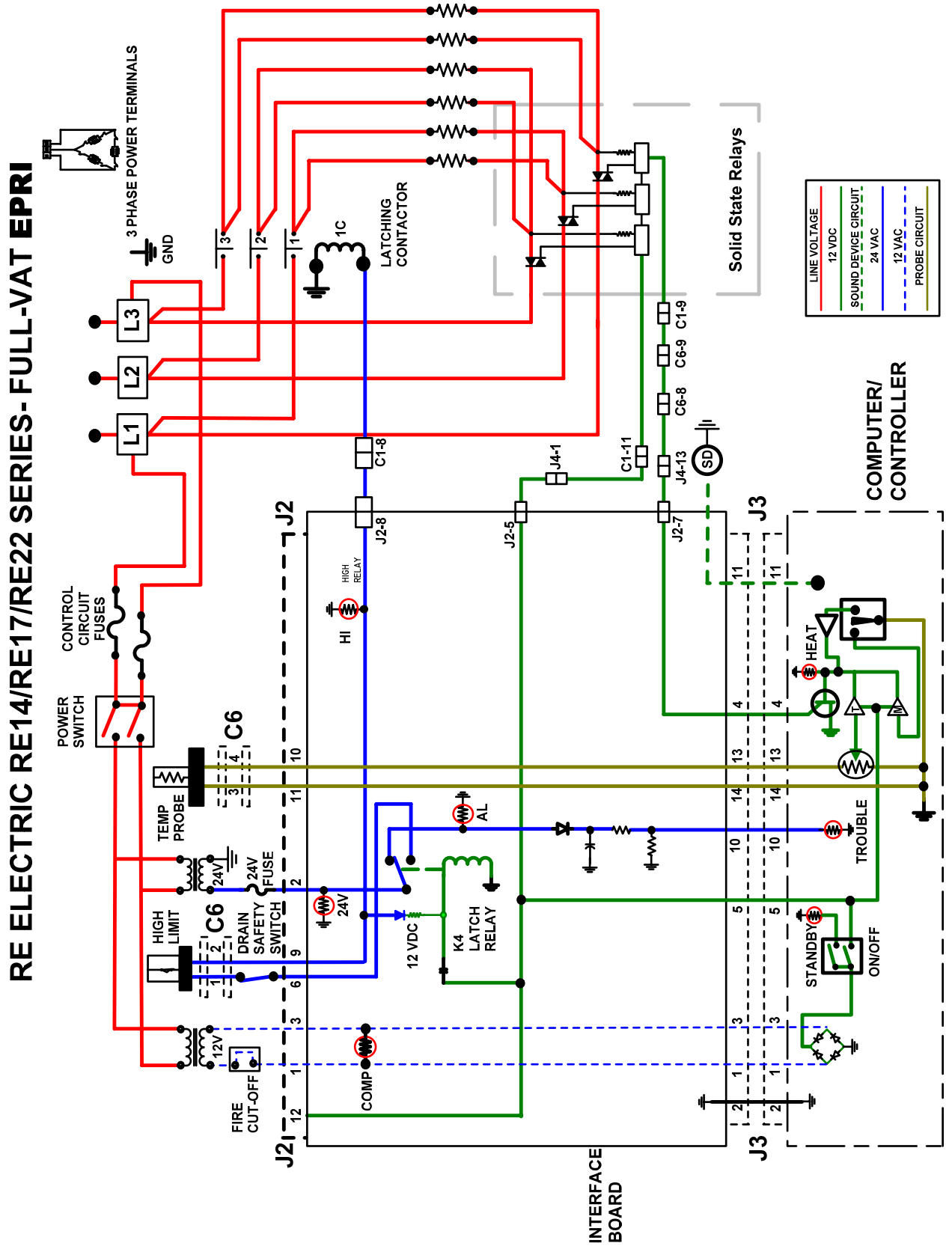

# 1.13.17 Simplified RE14/17/22 Series – Full Vat Wiring EPRI (EXPORT) WYE

## RE ELECTRIC RE14/RE17/RE22 SERIES-FULL-VAT EPRI WYE

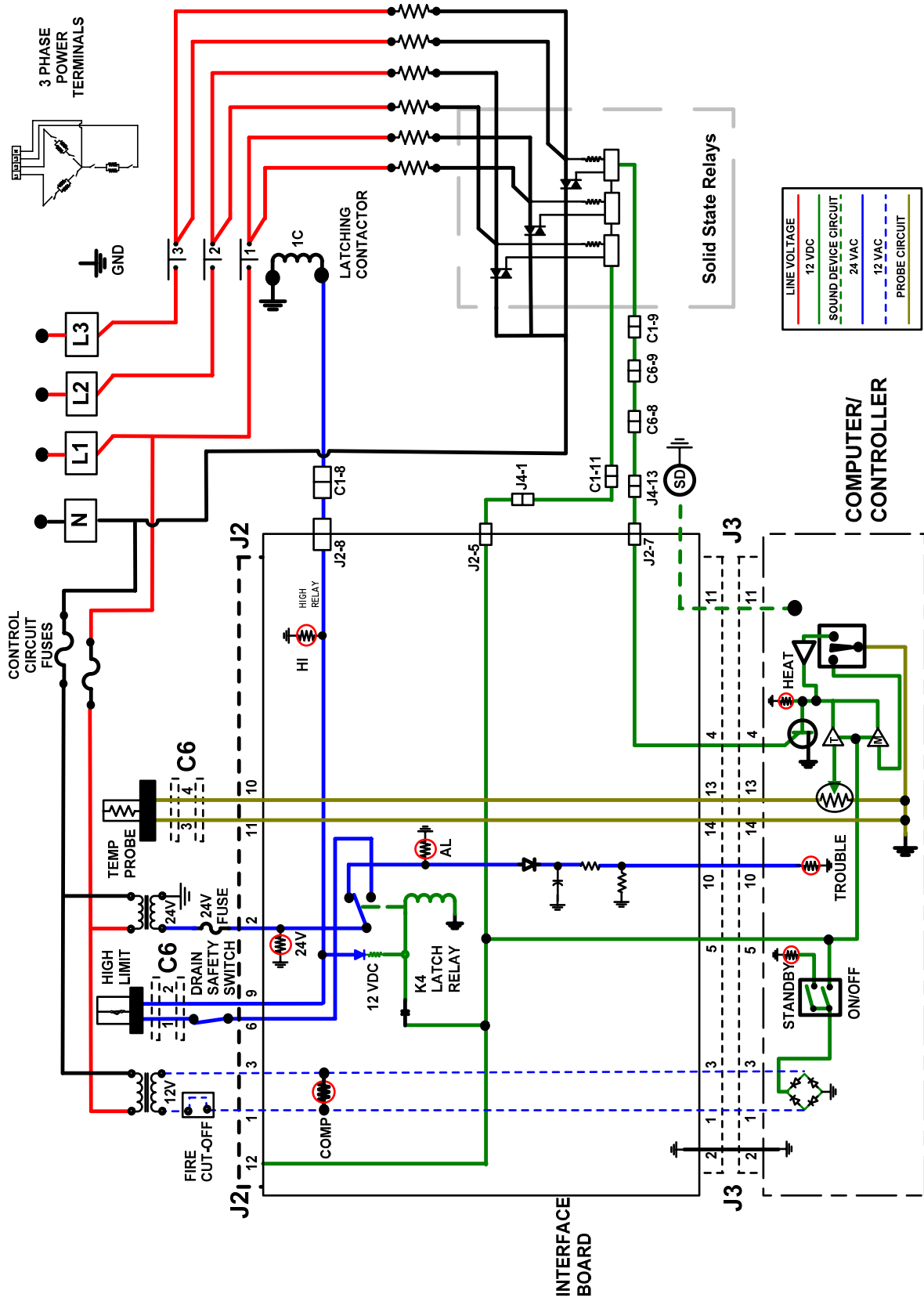

# RE SERIES E<sup>4</sup> ELECTRIC FRYERS

## CHAPTER 2: PARTS LIST

### 2.1 Accessories

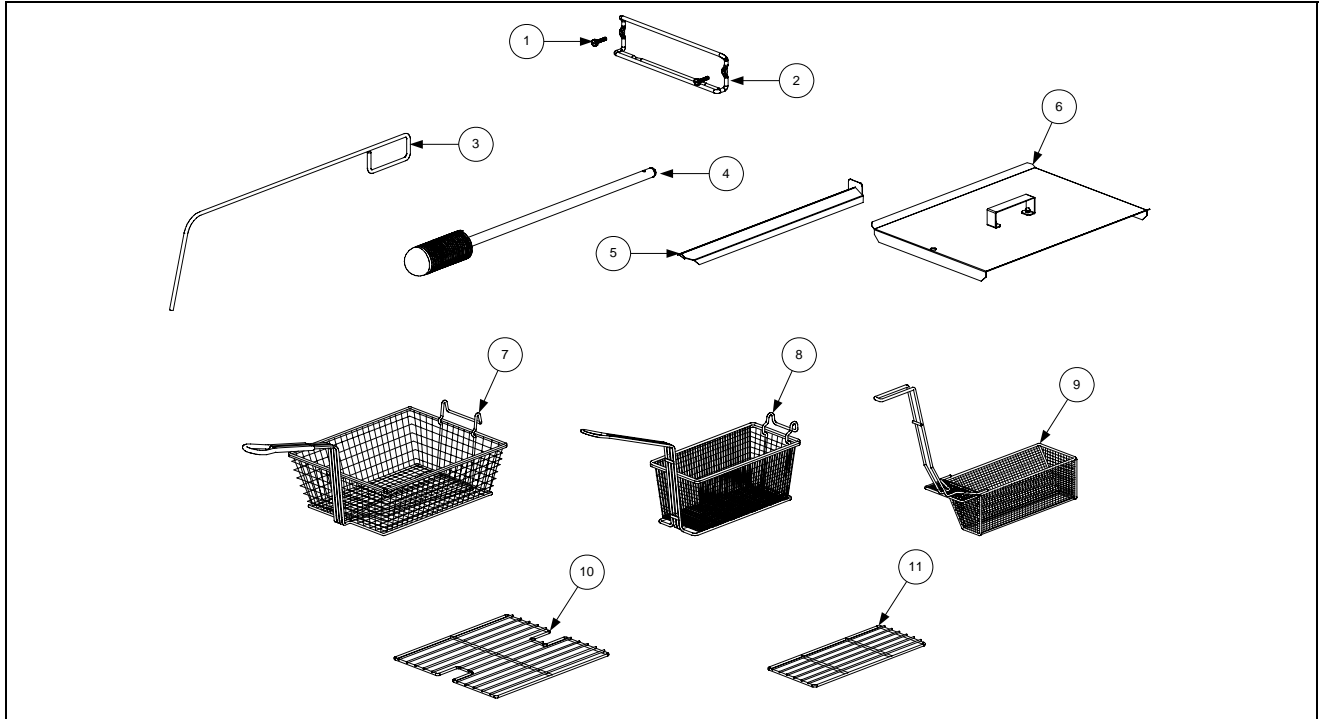

ITEM	PART #	COMPONENT
1	809-0171	Thumbscrew, ¼ -20 X 1¾-inch
2	810-2793	Hanger, Wireform Basket ( <i>use 810-2794 for Fryer ½</i> )
*	809-0921	Spacer, Basket Hanger
3	803-0197	Cleanout Rod, 27-inch
4	803-0209	Brush, Frypot
5	823-5772	Connecting Strip, Frypot ( <i>use 823-6000 for LH, use 823-5966 for RH Fryer ½</i> )
	823-5807	Connecting Strip, Frypot Deep Cabinet
6	806-3068	Cover, Full-Vat Frypot
	806-3071	Cover, Dual-Vat Frypot
	106-6349	Cover, Full-Vat Frypot Deep Cabinet
7	803-0099	Basket, Full-Vat
8	803-0271	Basket, Dual-Vat (Twin)
9	803-0122	Sediment Tray, Left Dual-Vat
*	803-0123	Sediment Tray, Right Dual-Vat
*	803-0113	Sediment Tray, Full-Vat ( <i>use 803-0365 for FV Deep Cabinet</i> )
10	803-0132	Rack, Full-Vat Basket Support ( <i>use 803-0364 for FV Deep Cabinet</i> )
11	803-0106	Rack, Dual-Vat Basket Support
*	824-1664	Spreader Pan
*	824-1720	Cover, Spreader Pan
*	807-1575	Heatlamp, Merco 120V 2 Bulb ( <i>use 806-5278SP for 120V Lamp Assembly</i> )
*	807-1576	Heatlamp, Merco 240V 2 Bulb ( <i>use 806-5285SP for 240V Lamp Assembly</i> )
*	803-0002	Powder, Filter (80 1-Cup Applications)
*	803-0170	Pack, 100-Sheet Filter Paper

\* Not illustrated.

## 2.2 Basket Lift Assembly and Associated Parts

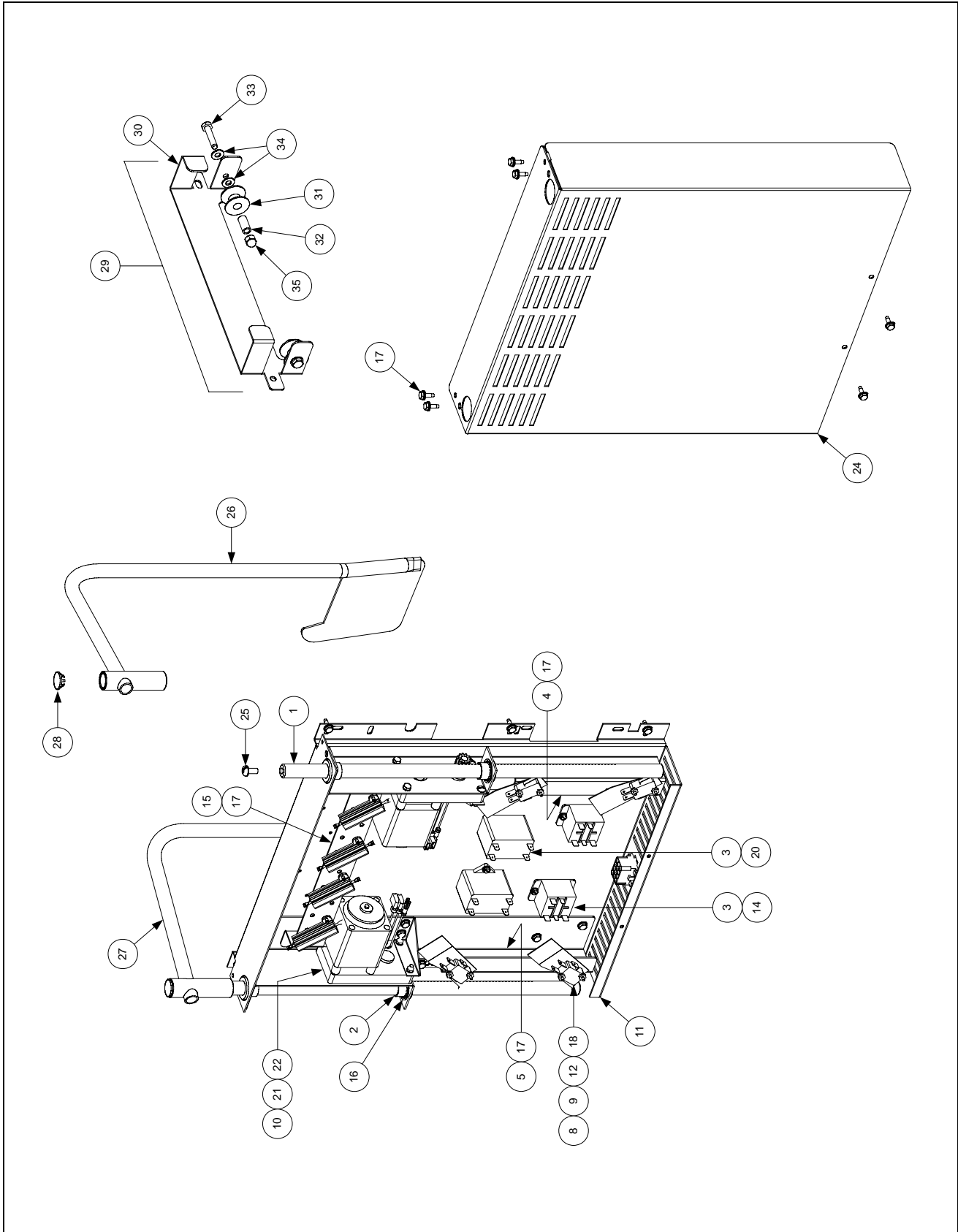

## 2.2 Basket Lift Assembly and Associated Parts cont.

ITEM	PART #	COMPONENT
	106-1805SP	Basket Lift Assembly, 200-220VAC w/Relay ( <i>Items 1-23</i> )
1	810-1012	Rod, Basket Lift
2	813-0035	Bushing, Bronze
3	807-2513	Capacitor, 12.5 $\mu$ Farad 330VAC
4	901-8499	Chassis, Left Basket Lift
5	902-8499	Chassis, Right Basket Lift
6	807-0159	Connector, 12-Pin Female
7	900-5529	Gusset, Basket Lift Motor
8	812-0442	Insulation, Microswitch
9	807-2572	Microswitch
10	806-5964SP	Motor Assembly, 208-240VAC Modular Basket Lift
11	200-2942	Mount, Modular Basket Lift
12	826-1366	Nut, 4-40 Hex Keps (Pkg. of 25)
13	809-0247	Nut, 8-32 Hex Keps
14	807-1683	Relay, 12VDC
15	106-2770SP	Resistor Assembly, 208-220VAC Modular Basket Lift
16	809-0082	Ring, Bushing Retainer
17	826-1374	Screw, #10 X 1/2-inch Hex Washer Head (Pkg. of 25)
18	826-1359	Screw, 4-40 X 3/4-inch Slotted Round Head (Pkg. of 25)
19	826-1361	Screw, 8-32 X 1-inch Slotted Truss Head (Pkg. of 25)
20	826-1371	Screw, #8 X 1/2-inch Drill Point Hex Head (Pkg. of 25)
21	809-0503	Screw, 8-32 X 1/2-inch Hex Head
22	809-0186	Washer, #8 Lock
23	WIR-0166SP	Wire Bundle, 200-250VAC Basket Lift w/Relay
24	910-4776	Cover, Modular Basket Lift Rear S/S ( <i>Use 900-4776 for Mild Steel</i> )
25	809-0127	Screw, 1/4-20 X 1/2-inch Slotted Round Head
26	823-2704	Arm, Left Basket Lift
27	823-2705	Arm, Right Basket Lift
28	810-0179	Button, Plug
29	806-9110SP	Roller Assembly, Basket Lift
30	910-8112	Bracket, Basket Lift Roller
31	810-0194	Roller, Basket Lift
32	810-0374	Spacer, Basket Lift Roller
33	809-0508	Bolt, 1/4-20 X 1 1/4 -Inch
34	809-0190	Washer, 1/4-inch Flat
35	809-0047	Nut, 1/4-20 Cap
*	106-5957	Wiring Harness, RE Series Electric Basket Lift ( <i>Plugs into Item 6</i> )

\* Not illustrated.

## 2.3 Cabinetry

### 2.3.1 Back Panels, Control Panel Frames, Doors, Sides, Tilt Housings, and Top Caps

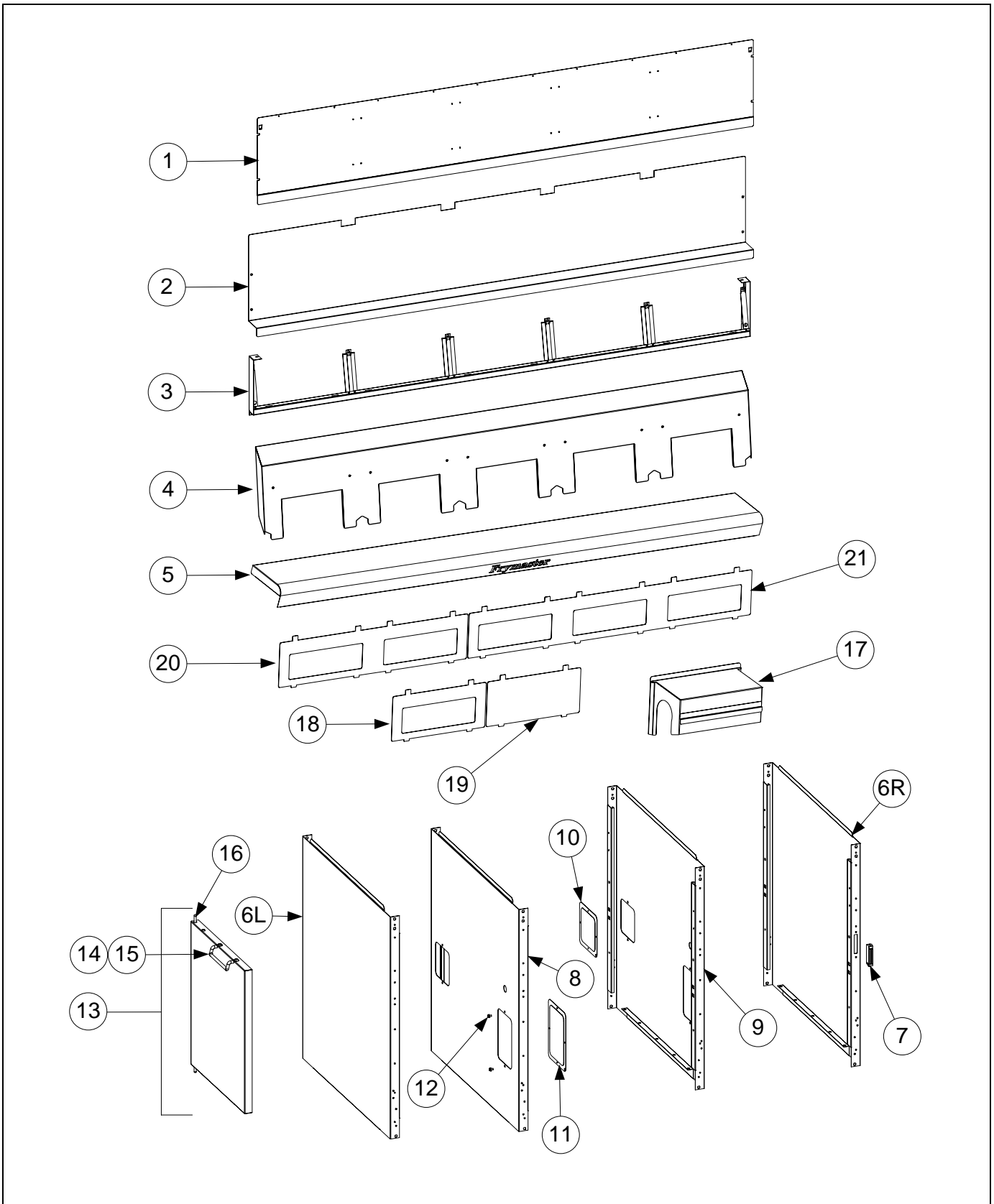

### 2.3.1 Back Panels, Control Panel Frames, Doors, Sides, Tilt Housings & Top Caps cont.

ITEM	PART #	COMPONENT
1		Back Panel, Upper (Panel for five station fryer shown)
	220-0421	Single Station Fryer CRS ( <i>Use 230-0422 for Stainless Steel</i> )
	220-1973	Fryer ½ Station Fryer CRS
	220-0419	Two Station Fryer CRS ( <i>Use 230-0420 for Stainless Steel</i> )
	220-0423	Three Station Fryer CRS ( <i>Use 230-0424 for Stainless Steel</i> )
	220-0425	Four Station Fryer CRS ( <i>Use 230-0546 for Stainless Steel</i> )
	220-0611	Five Station Fryer CRS ( <i>Use 230-0612 for Stainless Steel</i> )
2		Back Panel, Center (Panel for five station fryer shown)
	220-0501	Single Station Fryer CRS ( <i>Use 230-0502 for Stainless Steel</i> )
	220-1977	Fryer ½ Station Fryer CRS
	220-0487	Two Station Fryer CRS ( <i>Use 230-0490 for Stainless Steel</i> )
	220-0491	Three Station Fryer CRS ( <i>Use 230-0492 for Stainless Steel</i> )
	220-0499	Four Station Fryer CRS ( <i>Use 230-0500 for Stainless Steel</i> )
	220-0616	Five Station Fryer CRS ( <i>Use 230-0617 for Stainless Steel</i> )
3		Frame, Control Panel (Frame for five station fryer shown)
	106-5016	Single Station Fryer
	106-6846	Fryer ½ Station Fryer
	106-5221	Two Station Fryer
	106-5018	Three Station Fryer
	106-5019	Four Station Fryer
	106-5020	Five Station Fryer
4		Tilt Housing (Housing for five station fryer shown)
	823-5494	Single Station
	823-5999	Fryer ½ Station LH ½ fryer ( <i>use 823-5965 for RH ½ fryer</i> )
	823-5497	Two Station
	823-5489	Three Station
	823-5575	Four Station ( <i>use 106-7516 for Cracker Barrel</i> )
	823-5581	Five Station
5		Top Cap (Top cap for five station fryer shown)
	106-5195	Single Station ( <i>Also requires four 809-0079 1/4-20 Nutserts</i> )
	106-7060	Fryer ½ Station LH ½ fryer ( <i>use 106-6838 for RH ½ fryer</i> ) ( <i>Also requires four 809-0079 1/4-20 Nutserts</i> )
	106-5196	Two Station ( <i>Also requires four 809-0079 1/4-20 Nutserts</i> )
	106-5197	Three Station ( <i>Also requires six 809-0079 1/4-20 Nutserts</i> )
	106-5198	Four Station ( <i>Also requires eight 809-0079 1/4-20 Nutserts</i> )
	106-5199	Five Station ( <i>Also requires ten 809-0079 1/4-20 Nutserts</i> )
*		Heat Shield
*	200-9614	Single Station
*	200-9610	Two Station ( <i>Two are used on Four Station</i> ) ( <i>One used on Five Station</i> )
*	200-9611	Three Station ( <i>One used on Five Station</i> )
6L	231-0323	Side, Standard Cabinet Left SS ( <i>use 221-0323SP for Enameled Steel</i> )
	231-1345	Side, Left Deep Cabinet SS
6R	232-0323	Side, Standard Cabinet Right SS ( <i>use 222-0323SP for Enameled Steel</i> )
	232-1345	Side, Right Deep Cabinet SS
7	810-1105	Magnet, Door
8	231-0352	Side, Filter Ready Cabinet Left SS ( <i>use 221-0352 for Cold Rolled Steel</i> )
9	232-0352	Side, Filter Ready Cabinet Right SS ( <i>use 222-0352 for Cold Rolled Steel</i> )
10	910-0889	Cover, 5-inch X 5-inch Access
11	910-0890	Cover, 5-inch X 7-inch Access
12	809-0359	Screw, #8 X ¼-inch Hex Washer Head
13	106-4397	Door, Left or Right (Left shown – move handle to opposite side for Right) - Standard
	106-6899	Door, Left or Right – Fryer ½
14	809-0266	Screw, #10 X ½-inch Phillips Truss Head
15	210-9739	Handle, Eurolook Door ( <i>use 230-2088 for Fryer ½ handle</i> )

\* Not illustrated.

*continued on the following page...*

**2.3.1 Back Panels, Control Panel Frames, Doors, Sides, Tilt Housings & Top Caps  
cont.**

<b>ITEM</b>	<b>PART #</b>	<b>COMPONENT</b>
16	106-4067	Pin Assembly, Door
*	810-0275	Spring, Door Pin
*	809-0970	Retaining Ring
17	823-5440	Cove, Element Tilt Housing ( <i>use 823-5726 for Fryer 1/2</i> )
18	210-5046	Bezel, One-Controller ( <i>use 230-1953 for Fryer 1/2</i> )
19	210-5623	Bezel, Blank
20	210-5819	Bezel, Two-Controller
21	210-6698	Bezel, Three-Controller

\* Not illustrated.

### 2.3.2 Cabinets, Bases, Braces, and Associated Parts

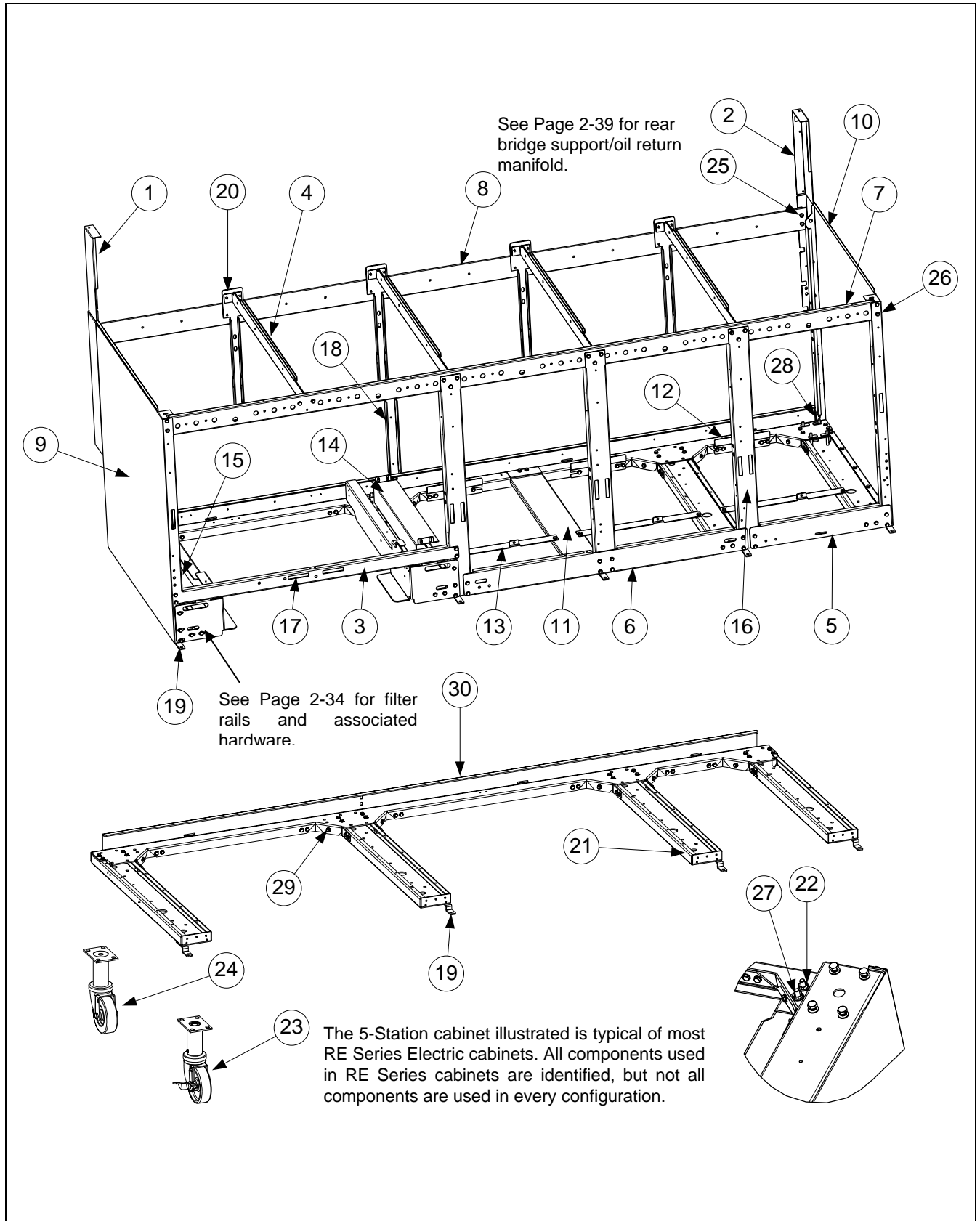

### 2.3.2 Cabinets, Bases, Braces, and Associated Parts cont.

ITEM	PART #	COMPONENT
1	106-3828	Upright Assembly, Left
2	106-3829	Upright Assembly, Right
3	200-1651	Support, Cross Cabinet <i>(use 220-1742 for Fryer ½)</i>
4	200-1659	Divider, Cabinet <i>(use 220-1348 for Deep Cabinet Divider)</i>
5	200-2293	Brace, Single Station Lower
6	200-3774	Brace, Double Station Lower
7		Brace, Front Horizontal
	200-7036	Single-Station Fryer <i>(use 220-0624 for Single-Station Lower Brace)</i>
	220-1740	Fryer ½ Station Fryer
	200-7037	Two-Station Fryer
	200-7038	Three-Station Fryer
	200-7039	Four-Station Fryer
	200-7040	Five-Station Fryer
8		Brace, Rear Horizontal
	200-5356	Single-Station Fryer
	220-1711	Fryer ½ Station Fryer
	200-2284	Two-Station Fryer
	200-2295	Three-Station Fryer
	200-2725	Four-Station Fryer
	200-3592	Five-Station Fryer
9	231-0323	Side, Cabinet LH S/S <i>(use 221-0323 for CRS)(use 231-1345 for Deep Cabinet)</i>
10	232-0323	Side, Cabinet RH S/S <i>(use 222-0323 for CRS)(use 232-1345 for Deep Cabinet)</i>
11	220-1100	Support, RE Bottom Contactor Box
12	220-1095	Support, RE Rear Contactor Box
13	220-1093	Brace, RE Front Contactor Box
*	220-1294	Brace, Contactor Box Single-Station Fryer Front
14	222-0610	Bracket, RH Contactor Box Mount <i>(use 222-1845 for Fryer ½)</i>
15	221-0610	Bracket, LH Contactor Box Mount <i>(use 221-1845 for Fryer ½)</i>
*	220-1446	Bracket, Contactor Box Mount SCF Deep Cabinet
*	200-6498	Bridge, Contactor Box Single-Station Fryer
16	200-4424	Post, Door
17	810-2346	Magnet, Door
18	200-4786	Support, Oil Return Manifold
19	210-6862	Hinge, Door
20	824-1393	Bracket, Rear Support <i>(use 200-8253 for Fryer ½)</i>
21	824-4557	Channel, Base Side
*	823-5782	Channel, Base Side SCF Deep Cabinet
*	221-0621	Channel, Base Left Side Single-Station Fryer <i>(use 222-0621 for RH side)</i>
22	809-0131	Bolt, ¼-20 X ¾-inch Hex Head <i>(also used w/Item 27 to mount filter rails)</i>
23	810-2970	Caster with Brake
24	810-1494	Caster without Brake
25	826-1376	Nut, 10-32 Keps Hex (Pkg. of 10)
26	826-1374	Screw, #10 X ½-inch Hex Washer Head <i>(primary cabinet screw)</i> (Pkg. of 25)
27	809-0417	Nut, ¼-20 Hex Flange
28	809-0429	Bolt, ¼-20 X 2-inch Hex Head
29	200-5417	Brace, Rear Channel Corner
30		Channel, Base Rear
	823-5589	Single-Station Fryer Base <i>(use 220-1737 for Fryer ½)</i>
	823-4558	Two-Station Fryer
	823-4560	Three-Station Fryer
	823-4561	Four-Station Fryer
	823-4562	Five-Station Fryer
*	810-1234	Leg, Stainless Steel 8.5-inch Adjustable <i>(mounts with Items 27 and 28)</i>
*	810-3010	Leg, Single Fryer Single-Station Fryer

\* Not illustrated.

## 2.4 Drain System Components

### 2.4.1 Drain Tube Sections and Associated Parts

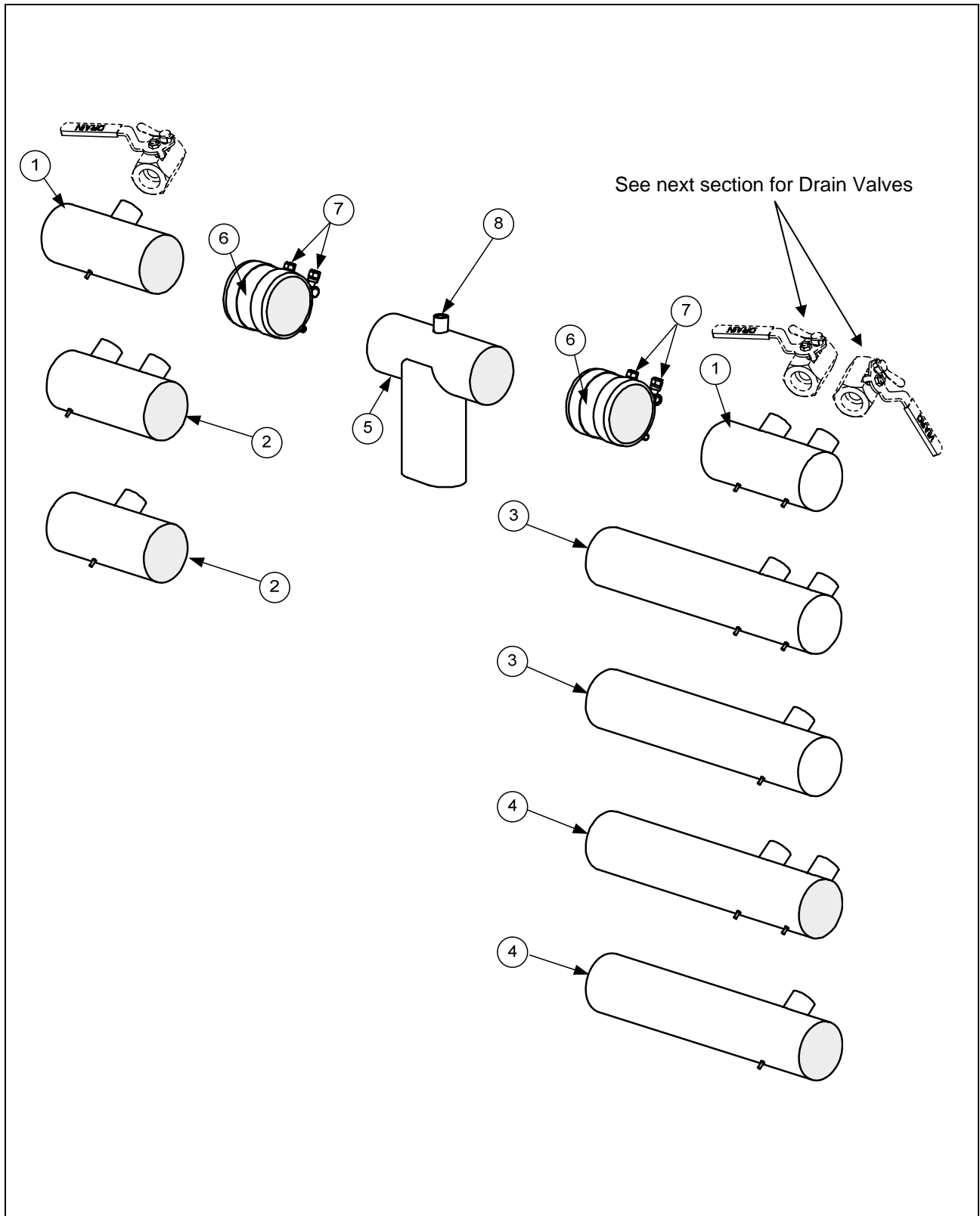

### 2.4.1 Euro-Look Drain Tube Sections and Associated Parts cont.

ITEM	PART#	COMPONENT
1		Drain Tube, Left/Right End Short
	823-4625	Full-Vat
	823-4624	Dual-Vat
	823-5943	Fryer ½, RH ½ Fryer
	823-6003	Fryer ½, LH ½ Fryer
2		Drain Tube, Left/Right Open Short
	823-4643	Full-Vat
	823-4642	Dual-Vat
3		Drain Tube, Right End Long
	823-4639	Full-Vat
	823-4638	Dual-Vat
4		Drain Tube, Left/Right Open Long
	823-4641	Full-Vat
	823-4640	Dual-Vat
5	823-4892	Drain Outlet Center Dump
	823-5944	Fryer ½, RH ½ Fryer
	823-6004	Fryer ½, LH ½ Fryer
6	816-0625	Sleeve
7	809-0969	Clamp
*	816-0630	Vinyl Cap
8	810-2492	Fitting, Quick-Connect Straight (receives Teflon vent tube)
*	KIT6033	Kit, Round Drain Clamp (contains 2 of Item 7 and 1 of Item 6)
*	811-1071	Tube, Teflon Vent (sold by the foot)

\* Not illustrated.

## 2.4.2 Drain Valves and Associated Parts (Units with Built-In Filtration)

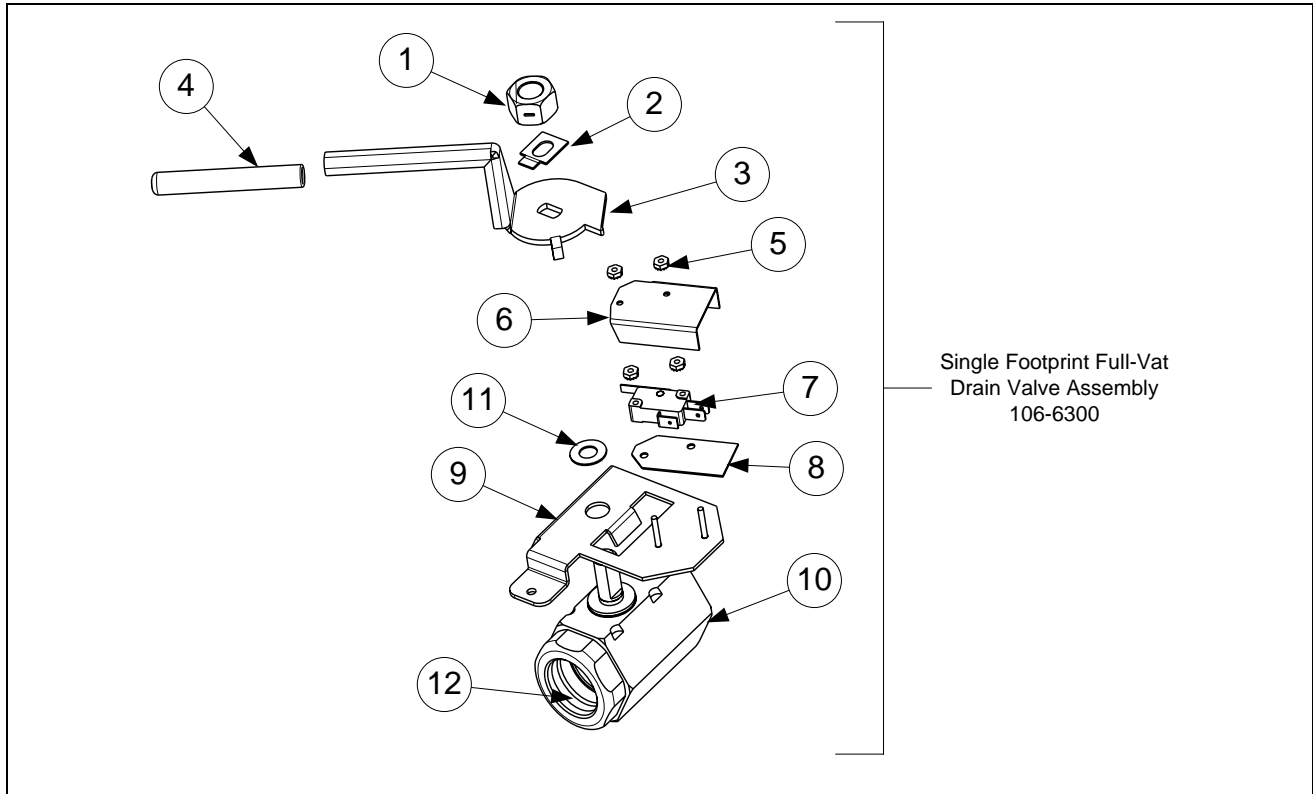

### 2.4.2 Drain Valves and Associated Parts (Units with Built-in Filtration) cont.

ITEM	PART #	COMPONENT
1	809-0540	Nut, 1/2-13 2-Way Hex Lock
2	900-2936	Retainer, Full-Vat Nut Drain Valve
3	824-1602	Handle, Full-Vat Drain Valve
4	816-0639	Cap, Red Handle
5	809-0237	Nut, 4-40 Keps Hex
6	901-2348	Cover, Dual Vat Drain Safety Switch
7	807-2103	Microswitch, CE Straight Lever
8	816-0220	Insulation, Drain Safety Switch
9	106-5391	Bracket Assembly, Full-Vat Drain Safety Switch Single FP Only
10	810-1018	Valve, 1.25-inch Full-Vat Drain
11	810-1165	Washer, Teflon Drain Valve
12	816-0135	O-Ring, Round Drain

## 2.4.2 Drain Valves and Associated Parts (Units with Built-In Filtration) cont

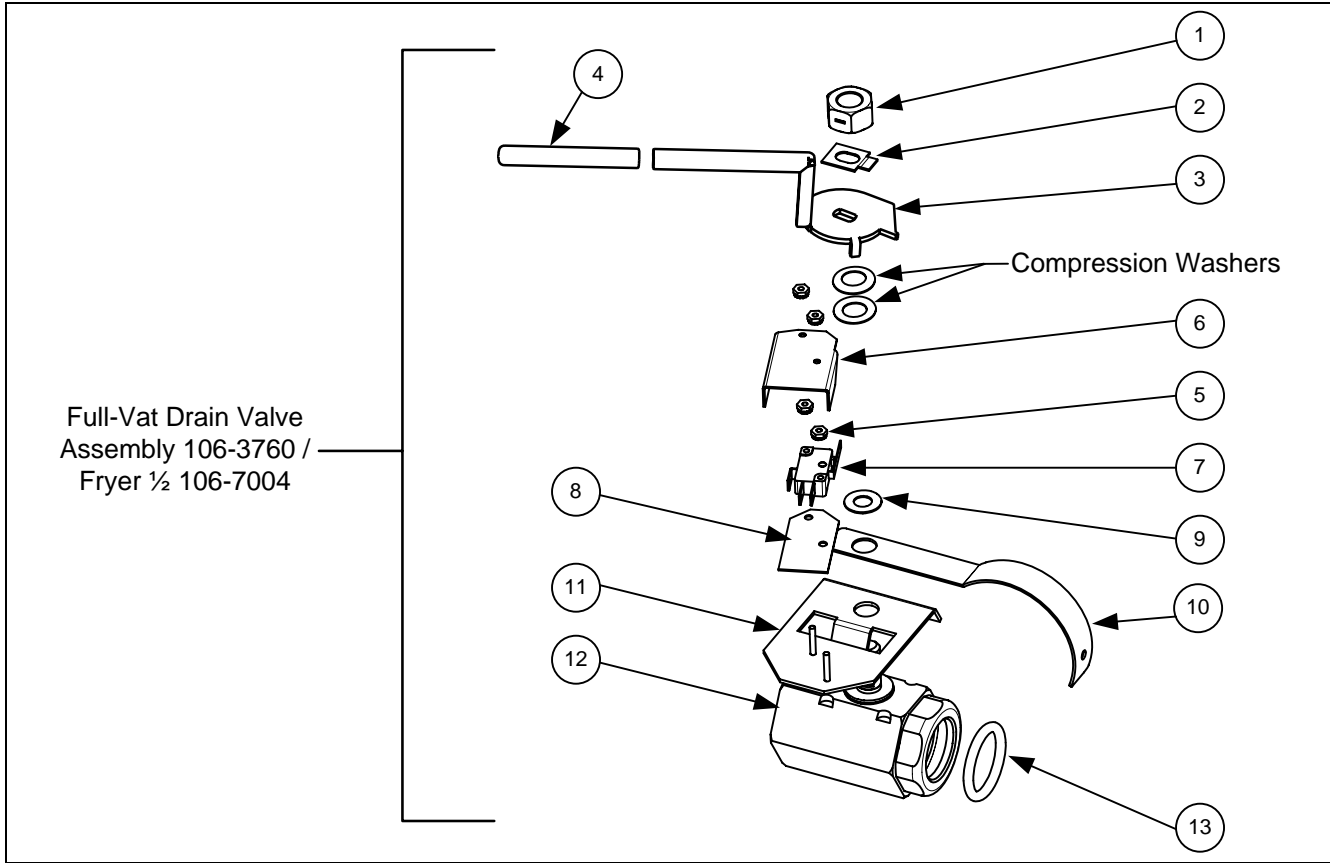

## 2.4.2 Drain Valves and Associated Parts (Units with Built-In Filtration) cont.

ITEM	PART#	COMPONENT
1	809-0540	Nut, ½-13 2-Way Hex Lock
2	900-2936	Retainer, Full-Vat Drain Valve Nut
3	824-1602	Handle, Full-Vat Drain Valve
	824-1740	Handle, Fryer ½ Half Vat
4	816-0639	Cap, Red Handle
5	809-0237	Nut, 4-40 Keps Hex
6	901-2348	Cover, Dual Vat Drain Safety Switch
7	807-2103	Microswitch, CE Straight Lever
8	816-0220	Insulation, Drain Safety Switch
9	810-1165	Washer, Teflon Drain Valve
10	200-6496	Support, 3" Drain
11	806-8137	Bracket Assembly, Full-Vat Drain Safety Switch
	106-7005	Bracket Assembly, Fryer ½
12	810-1018	Valve, 1.25-inch Full-Vat Drain
13	816-0135	Round Drain O-Ring

## 2.4.2 Drain Valves and Associated Parts (Units with Built-In Filtration) cont.

Dual-Vat Drain Valve  
Right Assembly  
106-5606 /  
106-6302 Single FP

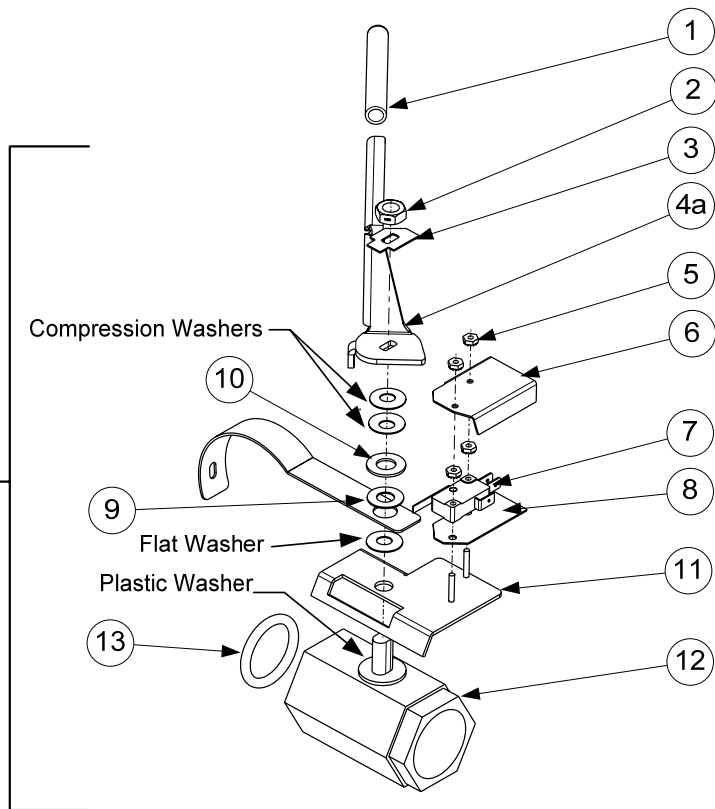

Dual-Vat Drain Valve  
Left Assembly  
106-5607 /  
106-6301 Single FP

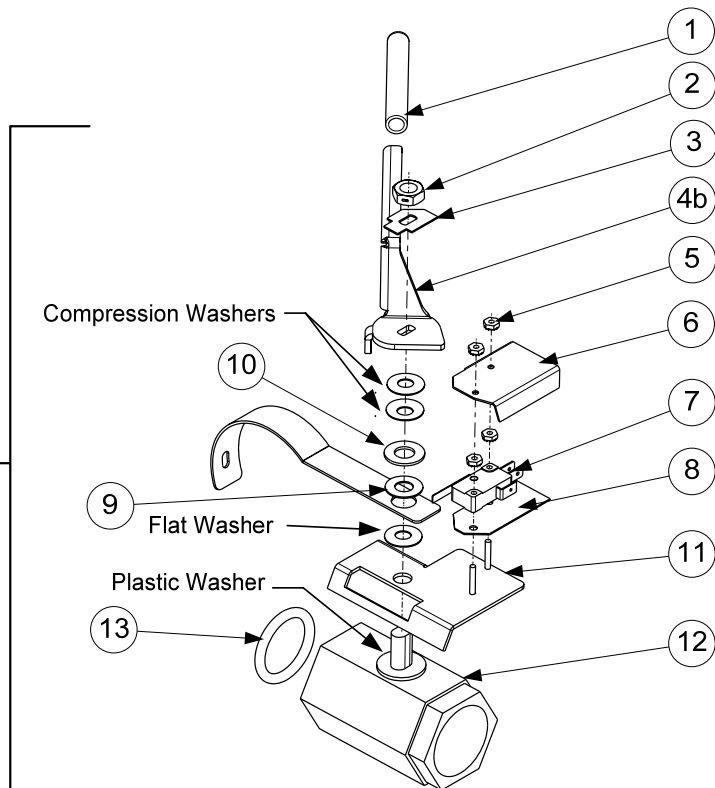

### 2.4.2 Drain Valves and Assoc. Parts (Units with Built-In Filtration) cont.

ITEM	PART#	COMPONENT
1	816-0639	Cap, Drain Handle
2	809-0539	Nut, 3/8-16 2-Way Hex Lock
3	900-2934	Retainer, Dual-Vat Drain Valve Nut
4a	824-1636	Handle, Dual-Vat Right Drain Valve
4b	824-1637	Handle, Dual-Vat Left Drain Valve
5	809-0237	Nut, 4-40 Keps Hex
6	901-2348	Cover, Dual Vat Drain Safety Switch
7	807-2103	Microswitch, CE Straight Lever
8	816-0220	Insulation, Drain Safety Switch
9	810-1165	Washer, Teflon Drain Valve
10	809-0196	Washer, 3/8-inch Flat
11	106-2671	Bracket Assembly, Dual-Vat Drain Safety Switch
	106-6304	Bracket Assembly, Dual-Vat Drain Safety Switch Single Footprint Only
12	810-1114	Valve, 1-inch Dual-Vat Drain
13	816-0135	Round Drain O-Ring
*	823-5592	Tube, Drain Single-Station Only with Filter

\* Not illustrated.

### 2.4.3 Drain Valves and Associated Parts (Units without Built-In Filtration)

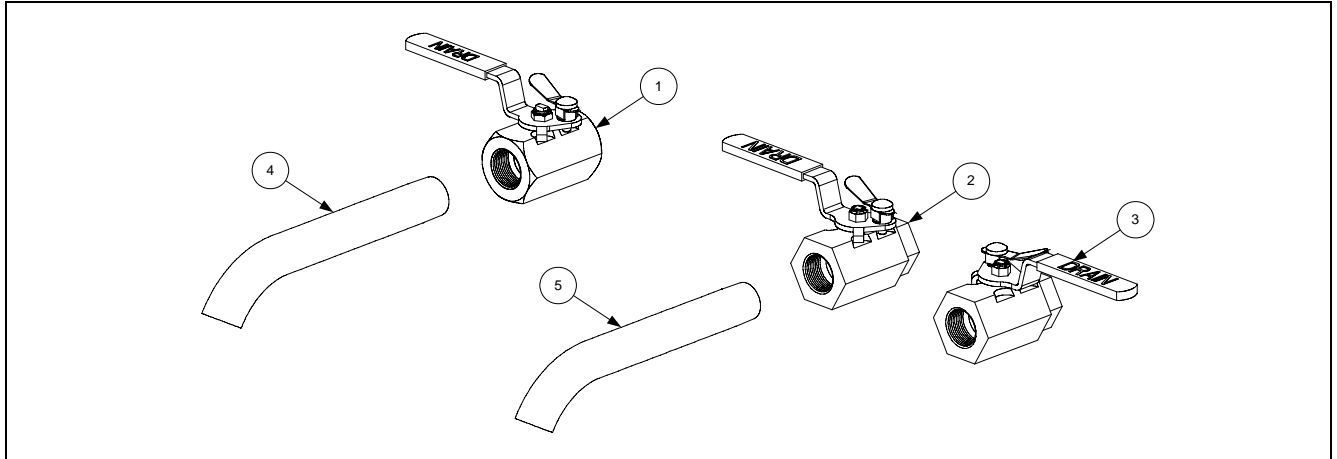

ITEM	PART #	COMPONENT
1	810-1569	Valve, 1.25-inch Non-Filter Full-Vat Drain
2	806-7915SP	Valve, 1-inch Non-Filter Dual-Vat Left Drain
3	806-7916SP	Valve, 1-inch Non-Filter Dual-Vat Right Drain
4	812-1226	Drain Extension, 1.25-inch
5	812-1227	Drain Extension, 1-inch

## 2.5 Electronics and Wiring Components

### 2.5.1 Component Boxes

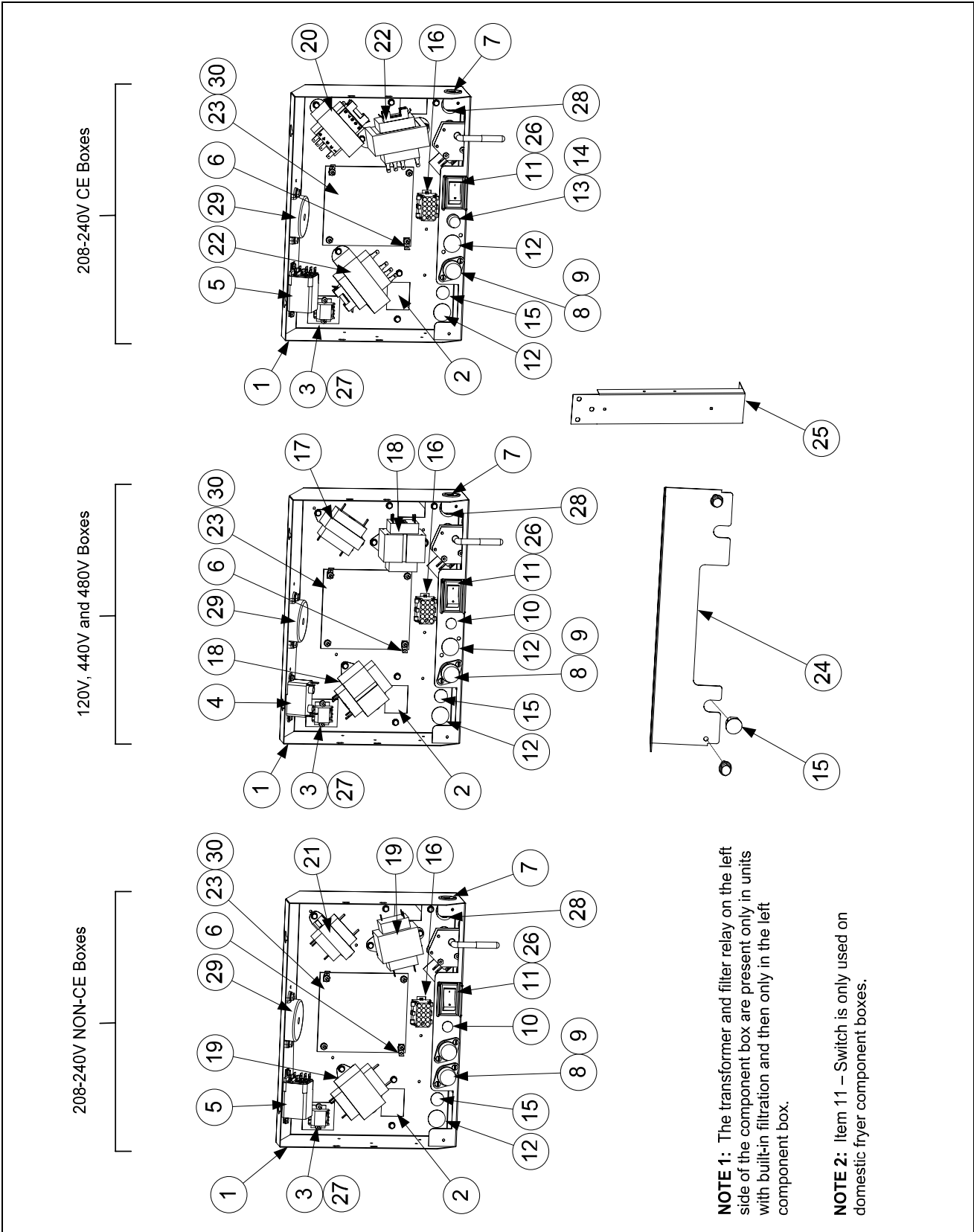

## 2.5.1 Component Boxes cont.

ITEM	PART #	COMPONENT
1	106-5592	Box Assembly, Component Standard
	106-6747	Box Assembly, Component Fryer ½
2	200-3300	Bracket, Component Box Strain Relief
3	806-9495SP	Terminal Block
√ 4	807-0012	Relay, Filter 18 Amp ⅓ HP 24V
√ 5	807-0670	Relay, Filter Mintex DPDT 24V
6	807-0037	Terminal, ¼-inch Push-on
7	807-0121	Bushing, Heyco Plastic AB-625-500
8	807-0922	Holder, Buss Fuse HPS
9	807-2278	Fuse, 20 Amp
10	810-2446	Plug, Button .50 Heyco Double "D"
√ 11	807-4036	Switch
	807-3575	Plug, Carling Switch Hole ( <i>used on some models without a switch</i> )
12	807-1947	Plug, Button .875 Dome
13	807-1321	Holder, AGC Panel Mount ¼" Fuse ( <i>Some models use item 10 here.</i> )
14	807-1597	Fuse, 3 AMP Slow-Blow
15	810-2445	Plug, Button .625 Heyco Double "D"
16	106-5750	Harness Assembly, RE FV Control
	106-5751	Harness Assembly, RE DV Control
√ 17	807-0855	Transformer, 100-120V/12V 20VA
√ 18	807-0800	Transformer, 100-120V/24V 50VA Filter
√	807-2181	Transformer, 100-120V/24V 62VA Filter
√ 19	807-0680	Transformer, 208-240V/24V 20VA Filter
√ 20	807-2191	Transformer, 208-240V/12V 30VA
√ 21	807-0979	Transformer, 208-240V/12V 43VA
√ 22	807-2180	Transformer, 208-240V 50VA Filter
*	807-3892	Transformer, 440/480 12/24V (used in non-filter fryers)
23		Interface Board ( <i>On SMT interface boards the relays are not replaceable.</i> )
√	826-2260	Standard, Full- or Dual-Vat ( <i>SMT</i> )
√	826-2261	EPRI, Full- or Dual-Vat
	826-2262	Fast Computer, Full- or Dual-Vat
*	807-3932	Relay, Latch/Heat 12VDC SPDT 12A Sealed ( <i>On SMT interface boards the relays are not replaceable.</i> )
*	106-6501	Fallback Controller Assembly RE
24	220-0565	Guard, Finger Domestic and Non-CE
	220-1061	Guard, Finger Non-Domestic and CE
25	200-6654	Brace, Component Box
26	230-0834	Guard, RE Box Switch
27	816-0217	Paper, Insulating Terminal Block
28	810-0045	Bushing, .875 Diameter 11/16"
√ 29	806-7179SP	Sound Device Std. ( <i>Use 810-3141 for SMT sound device with SMT connector</i> )
*	807-4330	Sound Device Adapter Harness ( <i>SMT</i> )
30	809-0349	Spacer, 4mm X 6mm Aluminum
*	826-2249	RE Hood/Ansul Interlock Kit (includes terminal block, wires and connectors)

\* Not illustrated.

√ Recommended parts.

## 2.5.2 Contactor Boxes

### 2.5.2.1 Left and Right Over the Filter Pan Contactor Box Configurations

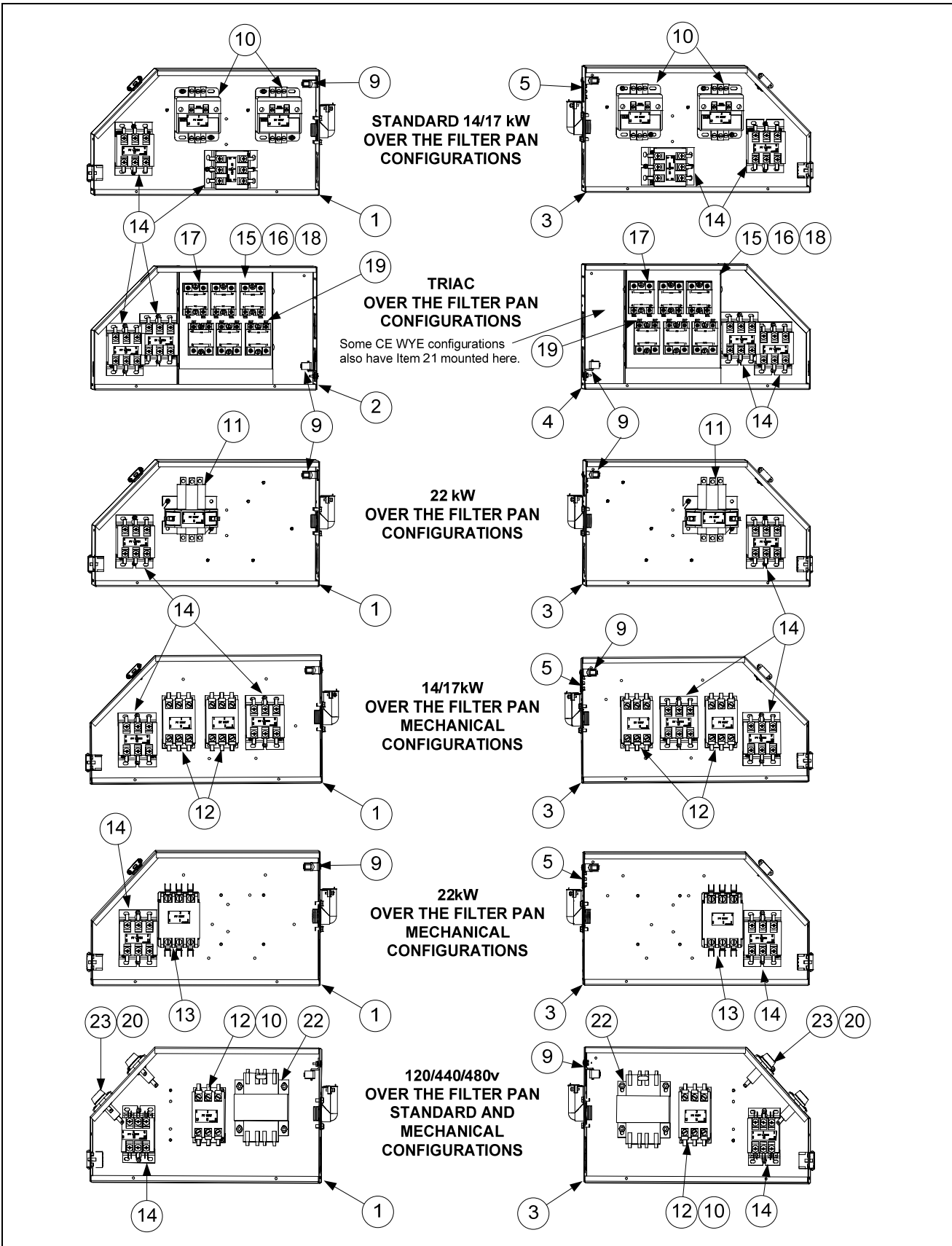

### 2.5.2.1 Left and Right Over the Filter Pan Contactor Box Configurations cont.

**NOTES:** Left and right contactor box assemblies are mirror images of one another. With the exception of the box itself, most components of a left-hand assembly are the same as those in the corresponding right-hand assembly and vice versa. The configurations illustrated show most possible components, but a particular configuration may not have all the components shown.

ITEM	PART #	COMPONENT
1	106-5488	Box Assembly, Left Contactor Standard (Over the Filter Pan)
	106-7066	Box Assembly, Left Contactor Fryer ½ Half Fryer on Left
2	823-5736	Box Assembly, Left Contactor <b>EPRI</b> (Over the Filter Pan)
3	106-5489	Box Assembly, Right Contactor Standard (Over the Filter Pan)
	106-6819	Box Assembly, Right Contactor Fryer ½ Half Fryer on Right
4	823-5748	Box Assembly, Right Contactor <b>EPRI</b> (Over the Filter Pan)
5	810-2554	Plug, Cord Cutout 1.125 Button
6	807-1947	Plug, .875 Diameter Dome
7	807-0064	Transformer, 480V/120V 150VA
8	807-0922	Holder, Bus Fuse
*	221-0482	Cover, Left Hand Standard Contactor Box
	222-2072	Cover, Left Hand Fryer ½ Half fryer on Left
*	222-0482	Cover, Right Hand Standard Contactor Box
	220-1912	Cover, Right Hand Fryer ½ Half fryer on Right
9	807-0070	Terminal, Ground Lug
√ 10	807-1071	Contactor, 24V 30 Amp Mercury
√ 11	807-0884	Contactor, 24V 50 Amp Mercury
√ 12	807-2284	Contactor, 24V 50 Amp Mechanical ( <i>only in 14kW &amp; 17kW units</i> )
√ 13	807-2283	Contactor, 24V 63 Amp Mechanical ( <i>only in 22kW units</i> )
√ 14	810-1202	Contactor, 24V 40 Amp Mechanical
15**	806-8674	Heatsink Assembly, DV Solid State Relay (See components below)
16**	806-8673	Heatsink Assembly, FV Solid State Relay (See components below)
		Components of Items 15 and 16
√ 17	826-1562	Kit Relay, Solid State 40 Amp 280V with Heatsink
18	807-2749	Heatsink, Solid State
19	807-0037	Terminal, ¼-inch Push-on
20	807-2278	Fuse, 20 Amp
21	106-6204	Filter Assembly, EPRI ( <i>used in CE WYE-configured EPRI units only</i> )
22	807-0922	Holder, Bus Fuse
*	221-0610	Bracket, Left Hand Contactor Box Mounting
*	222-0610	Bracket, Right Hand Contactor Box Mounting
*	807-0012	Relay, Tilt Switch 18 Amp 1/3 HP 24 V Coil

\* Not illustrated.      \*\* Full Vat has three relays 826-1562, Dual-Vat has six relays.

√ Recommended parts.

### 2.5.2.2 Large Center Contactor Box Configurations (Non-Filter, Not over the Filter and Single Units)

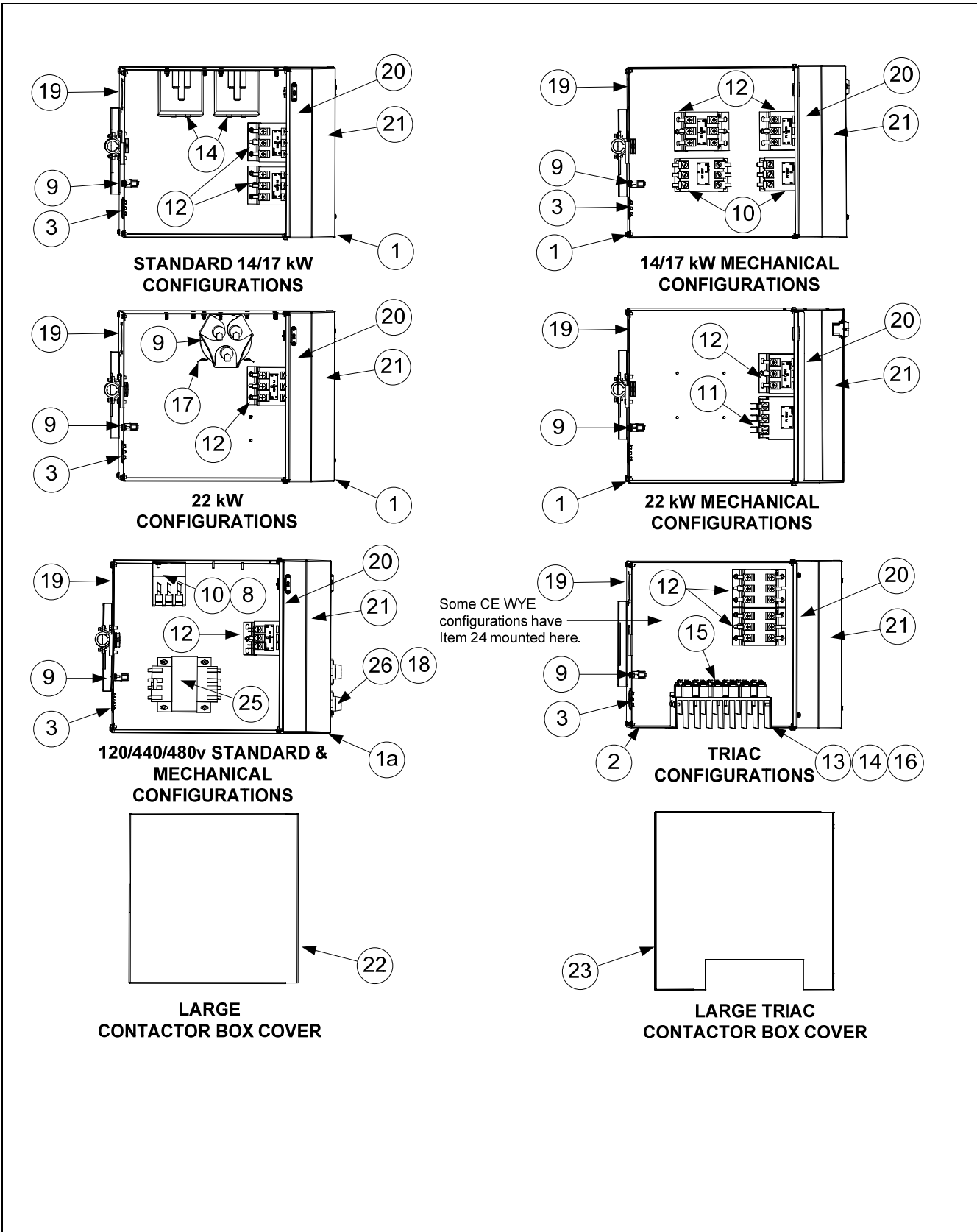

**2.5.2.2 Large Center Contactor Box Configurations (Non-Filter, Not Over the Filter and Single Units) cont.**

<b>ITEM</b>	<b>PART #</b>	<b>COMPONENT</b>
1	106-6081	Box Assembly, Contactor (Non-Filter or Not Over the Filter Pan)
1a	106-6255	Box, Assembly Contactor (Non-Filter or Not Over the Filter Pan) <i>120/440/480V</i>
2	106-6173	Box Assembly, Contactor <b>EPRI</b> (Non-Filter or Not Over the Filter Pan)
*	106-6244	Box Assembly, Contactor Single-Station Fryer Only
3	810-2554	Plug, Cord Cutout 1.125 Button
4	807-1947	Plug, .875 Diameter Dome
5	221-0482	Cover, Left Hand Contactor Box
6	222-0482	Cover, Right Hand Contactor Box
7	807-0070	Terminal, Ground Lug
√ 8	807-1071	Contactor, 24V 30 Amp Mercury
√ 9	807-0884	Contactor, 24V 50 Amp Mercury
√ 10	807-2284	Contactor, 24V 50 Amp Mechanical ( <i>only in 14kW &amp; 17kW units</i> )
√ 11	807-2283	Contactor, 24V 63 Amp Mechanical ( <i>only in 22kW units</i> )
√ 12	810-1202	Contactor, 600V 40 Amp 3-Pole
13**	806-8674	Heatsink Assembly, DV Solid State Relay (See components below)
14**	806-8673	Heatsink Assembly, FV Solid State Relay (See components below)
		Components of Items 13 and 14
√ 15	826-1562	Kit Relay, Solid State 40 Amp 280V with Heatsink
16	807-2749	Heatsink, Solid State
17	807-0037	Terminal, ¼-inch Push-on
18	807-2278	Fuse, 20 Amp
19	823-5729	Plate, Contactor Back Cordset
20	220-1087	Bracket, Box Connecting
21	220-1088	Cover, Contactor Box Front
22	220-1089	Cover, Contactor Box Top (Non-Filter or Not Over the Filter Pan)
*	220-1175	Cover, Contactor Box Top Full Vat Single-Station Fryer Only
*	220-1373	Cover, Contactor Box Top Dual Vat Single-Station Fryer Only
23	220-1152	Cover, Contactor Box Top <b>EPRI</b> (Non-Filter or Not Over the Filter Pan)
24	106-6204	Filter Assembly, EPRI ( <i>used in CE WYE-configured EPRI units only</i> )
√ 25	807-0064	Transformer, 480V/120V 150VA
26	807-0922	Holder, Bus Fuse
*	807-0012	Relay, Tilt Switch 18 Amp 1/3 HP 24 V Coil

\*Not illustrated. \*\* Full Vat has three relays 826-1562, Dual-Vat has six relays.

√ Recommended parts.

### 2.5.3 Fuse Boxes

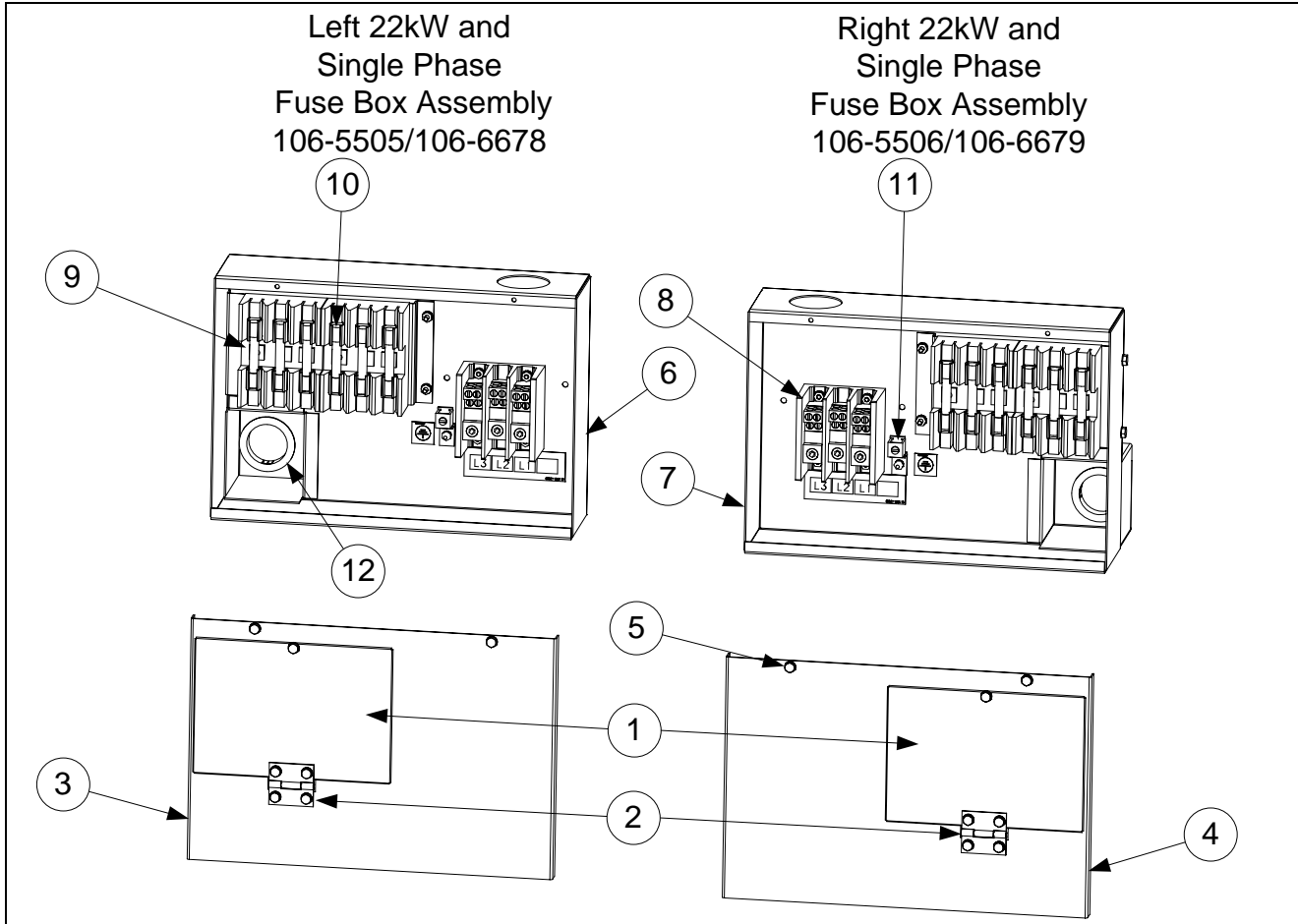

ITEM	PART #	COMPONENT
1	200-2334	Door
2	810-0519	Hinge
3	221-0523	Cover, LH Fuse Box
4	222-0523	Cover, RH Fuse Box ( <i>Used on Single Station Fryers also</i> )
5	809-0434	Screw, #10 x 3/8" Hex
6	823-5585	Box, LH Fuse
7	823-5557	Box, RH Fuse
	823-5797	Box, Single Station Fryer Only
8	807-3970	Block, 3 Pole 600V 175A Terminal
9	807-0501	Fuse Block, Buss #2968 3-Pole
10	807-2240	Fuse, 60 AMP 300VAC
11	807-0070	Terminal, Ground Lug
12	807-0128	Bushing, Insulating Heyco

## 2.5.4 Terminal Blocks

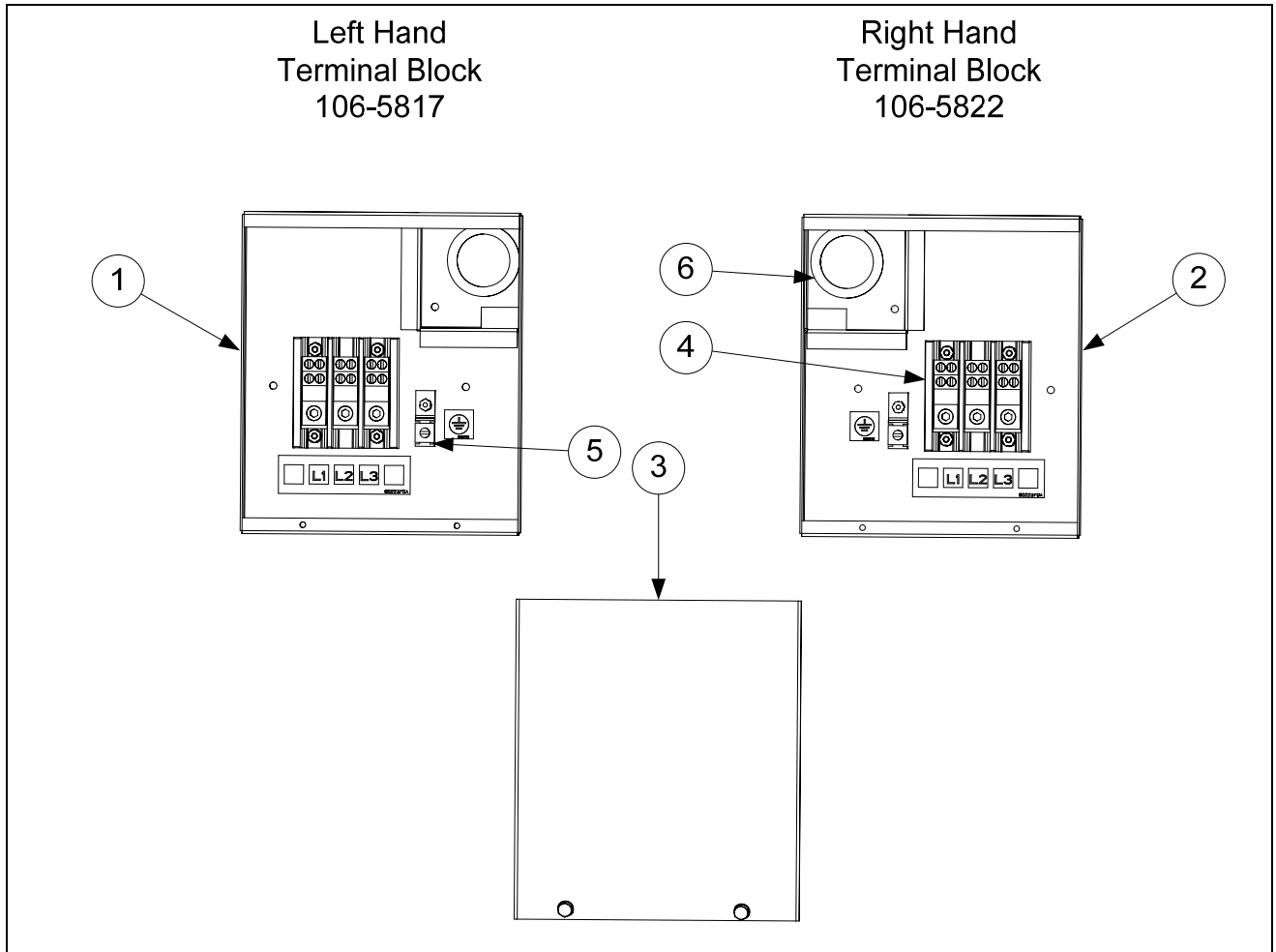

ITEM	PART #	COMPONENT
1	823-5631	Box, LH Rear Terminal Block
2	823-5632	Box, RH Rear Terminal Block
	823-5797	Box, Single Station Fryer Only ( <i>see previous page for cover 222-0523</i> )
3	220-0801	Cover, Rear Terminal Block Box
4	807-3970	Block, 3 Pole 600V 175A
5	807-0070	Terminal, Ground Lug
6	807-0128	Bushing, Insulating Heyco

## 2.5.5 Heating Element Assemblies and Associated Parts

### 2.5.5.1 Element Assemblies and Hardware

**FULL-VAT ELEMENT ASSEMBLY**

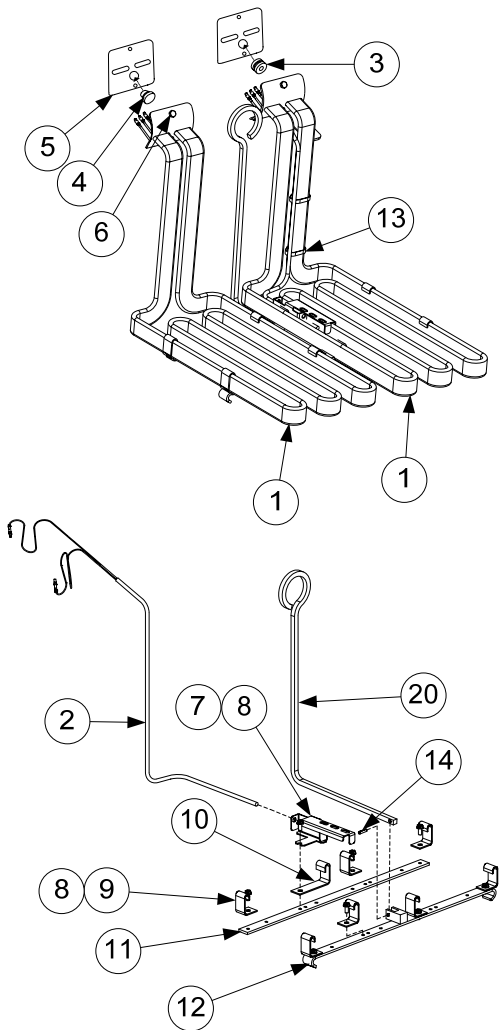

**DUAL-VAT ELEMENT ASSEMBLY**

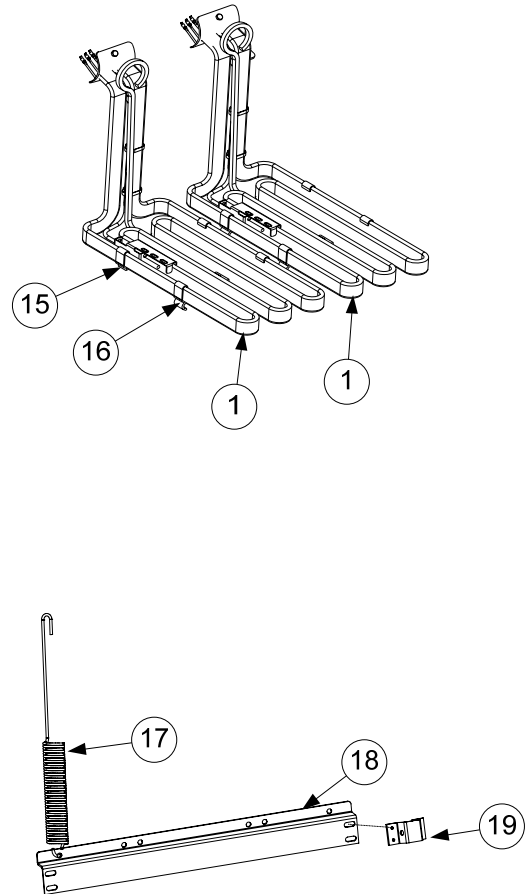

**NOTES:**

The dual-vat assembly is almost the same as the full-vat assembly except for having two of Items 2, 3, 7, 14, 15, 16 and 20. The only difference between element assemblies for different voltage and kW ratings is the element itself (Item 1).

Items 17, 18 and 19 are shown as associated parts. They are not part of either assembly.

**NOTE: These elements apply only to the RE series fryers.  
For the previous model elements see manual PN 819-5990.**

### 2.5.5.1 Heating Element Assemblies and Associated Parts cont.

ITEM	PART #	COMPONENT
1		Element Kits – <i>includes gaskets, grommets, tie wraps, screws and nuts.</i>
	826-2198	200V 7.0 kW (also used for 220V 8.5 kW)
	826-2201	200V 8.5 kW
	826-2208	200V 11.0 kW
√	826-2192	208V 7.0 kW
√	826-2197	208V 8.5 kW
	826-2210	208V 11.0 kW
	826-2200	220V 7.0 kW (also used for 240V 8.5 kW)
	826-2205	220V 11.0 kW
	826-2193	230V 7.0 kW
	826-2199	230V 8.5 kW
	826-2206	230V 11.0 kW
	826-2194	240V 7.0 kW
	826-2207	240V 11.0 kW
	826-2204	400V 8.5kW
	826-2195	440V 7.0 kW
	826-2202	440V 8.5 kW
	826-2211	440V 11.0 kW
	826-2196	480V 7.0 kW
	826-2203	480V 8.5 kW
	826-2209	480V 11.0 kW
√	2	Probe, Temperature RE – <i>includes tie wraps and grommet.</i>
	807-4324	Probe, Temperature Fast Ready
	3	Grommet, Probe
	4	Plug, .375-inch Dome
	5	Gasket, Element
	6	Screw, 10-32 X 3/8-inch Hex Head SS
	*	Nut, 10-32 Keps Hex Head SS
	7	Bracket, Temperature Probe
	8	Screw, 8-32 X 3/8-inch Slotted Hex Head
	9	Clamp, Element (Short)
	10	Clamp, Element (Long)
	11	Support, Full-Vat Element Rear
	12	Support, Full-Vat Element Front ( <i>use 823-5621 for 17kW Front Support</i> )
	13	Tie-Wrap, Metal
	14	Pin, .125 X .5-inch Split
	15	Support, Dual-Vat Element Rear Dual Vat
	16	Support, Dual-Vat Element Front Dual Vat 14kW
		823-5627 Support, Dual-Vat Element Front Dual Vat 17kW
	17	Spring, Element Lift Left
		810-3031 Spring, Element Lift Right
	18	Bracket, Lower Spring Single Foot Print
		220-0464 Bracket, Lower Spring
		220-1855 Bracket, Lower Spring Fryer 1/2
	19	Bracket, Lower Spring Mating
	20	Handle, Element Lift

**The wire harnesses must be replaced when replacing 22kW elements on all fryers, except 440V and 480V, manufactured before March 2007. (See Page 2-30 for wire harnesses.)**

\* Not illustrated.

√ Recommended parts.

### 2.5.5.2 Element Tube Assemblies

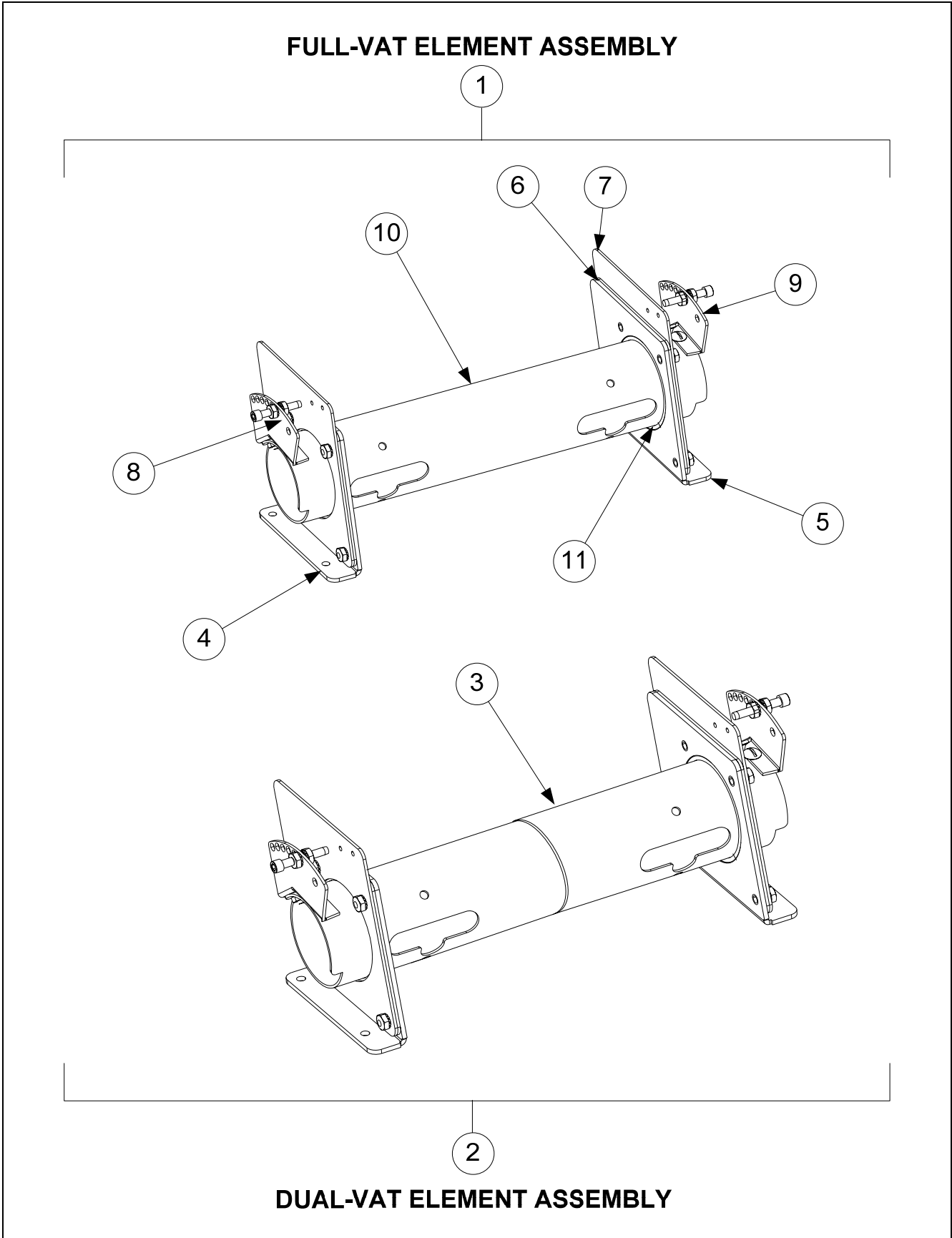

### 2.5.5.2 Element Tube Assemblies cont.

ITEM	PART #	COMPONENT
1	106-7653SP	Tube Assembly RE Element, Full-Vat
	106-6736	Tube Assembly RE Element Fryer ½ LH Half Fryer ( <i>use 106-6061 RH Half Fryer</i> )
2	106-7654SP	Tube Assembly RE Element, Dual-Vat
3	810-3246	Bushing and Tube Assembly, Dual-Vat
4	106-5329	Bracket Assembly, LH Element Tube Support
5	106-5330	Bracket Assembly, RH Element Tube Support
6	220-0122	Plate, Element Tube Support Inner
7	220-0123	Plate, Element Tube Support Outer
8	106-7651	Bracket Assembly, LH Upper Spring ( <i>use 106-6569 for 17kW</i> )
9	106-7652	Bracket Assembly, RH Upper Spring ( <i>use 106-6570 for 17kW</i> )
10	810-2992	Tube, FV Element Mounting
	810-3135	Tube, Fryer ½ LH Half Fryer ( <i>use 810-3036 RH Half Fryer</i> )
11	810-2993	Bushing, Tube End Teflon
*	809-0766	Nut, 10-32 Hex HD SS
*	106-6587	Magnetic Position Sensor Assembly
*	106-6588	Magnetic Position Sensor Assembly with Bracket
*	810-3007	Magnet
*	230-0794	Bracket, Magnetic Position Sensor Wire

\* Not illustrated.

### 2.5.6 Controllers

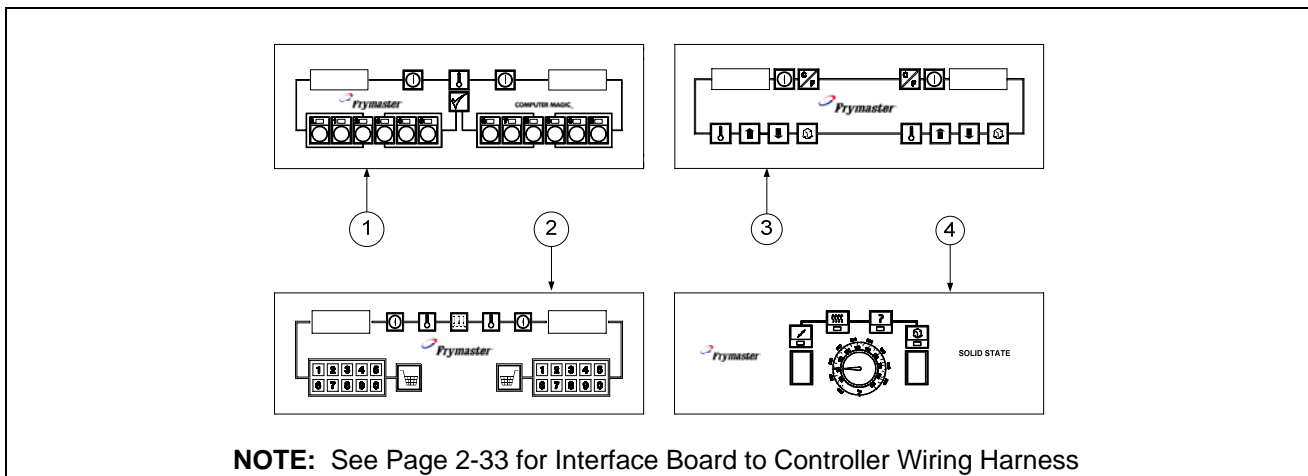

**NOTE:** See Page 2-33 for Interface Board to Controller Wiring Harness

ITEM	PART #	COMPONENT
1		Computer Magic III.5
√	826-2395	Full-Vat (CE)
	826-2396	Dual-Vat (CE)
√	826-2332	Full-Vat (Non-CE)
	826-2405	Dual-Vat (Non-CE)
	826-2397	Full-Vat (EPRI/Solid State)
	826-2398	Dual-Vat (EPRI/Solid State)
2		Digital Controller
	826-2399	Full-Vat (CE)
	826-2400	Dual-Vat (CE)
	826-2329	Full-Vat (Non-CE)
	826-2476	Dual-Vat (Non-CE)

√ Recommended parts.

*continued on the following page*

### 2.5.6 Controllers cont.

ITEM	PART #	COMPONENT
3		Basket Lift Timer
	826-2330	Full-Vat (CE)
	106-4366	Dual-Vat (CE)
	826-2401	Full-Vat (Non-CE)
	826-2402	Dual-Vat (Non-CE)
4		Solid-State (Analog) Controller
	826-2538	Full-Vat
	106-4334	Dual-Vat
*	802-2021	Graphic Sheet of Symbols

### 2.5.7 Wiring

#### 2.5.7.1 Contactor Box Wiring Assemblies – 12-Pin Dual-Vat C-1

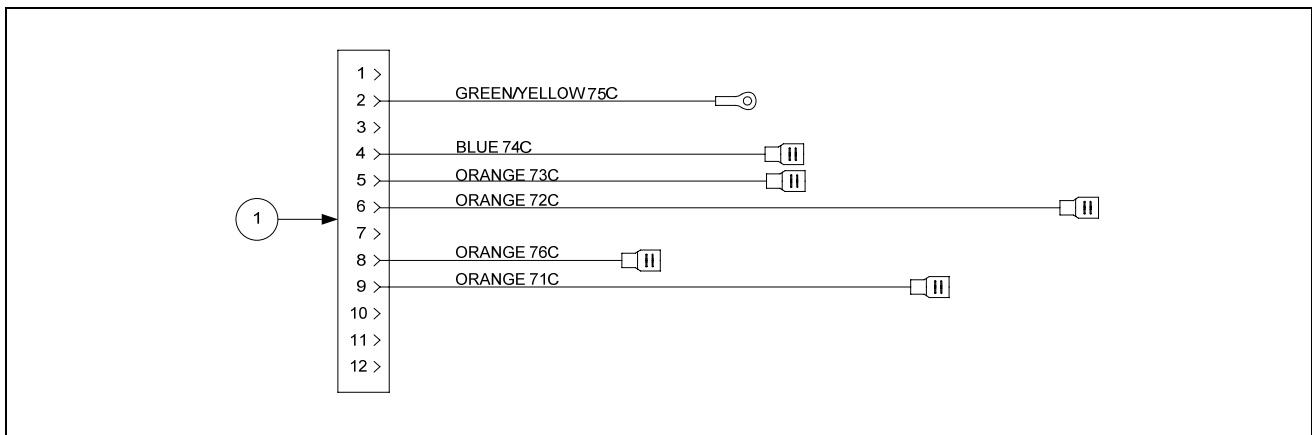

ITEM	PART #	COMPONENT
	106-5980SP	Contactor Box Harness Assembly Dual Vat
1		Standard (See wiring diagrams on pages 1-19.)
		EPRI (uses harness above plus wire kits WIR0734 and WIR0737)
		(See wiring diagrams on pages 1-26 and 1-27.)

### 2.5.7.2 Contactor Box Wiring Assemblies – 12-Pin Full-Vat C-1

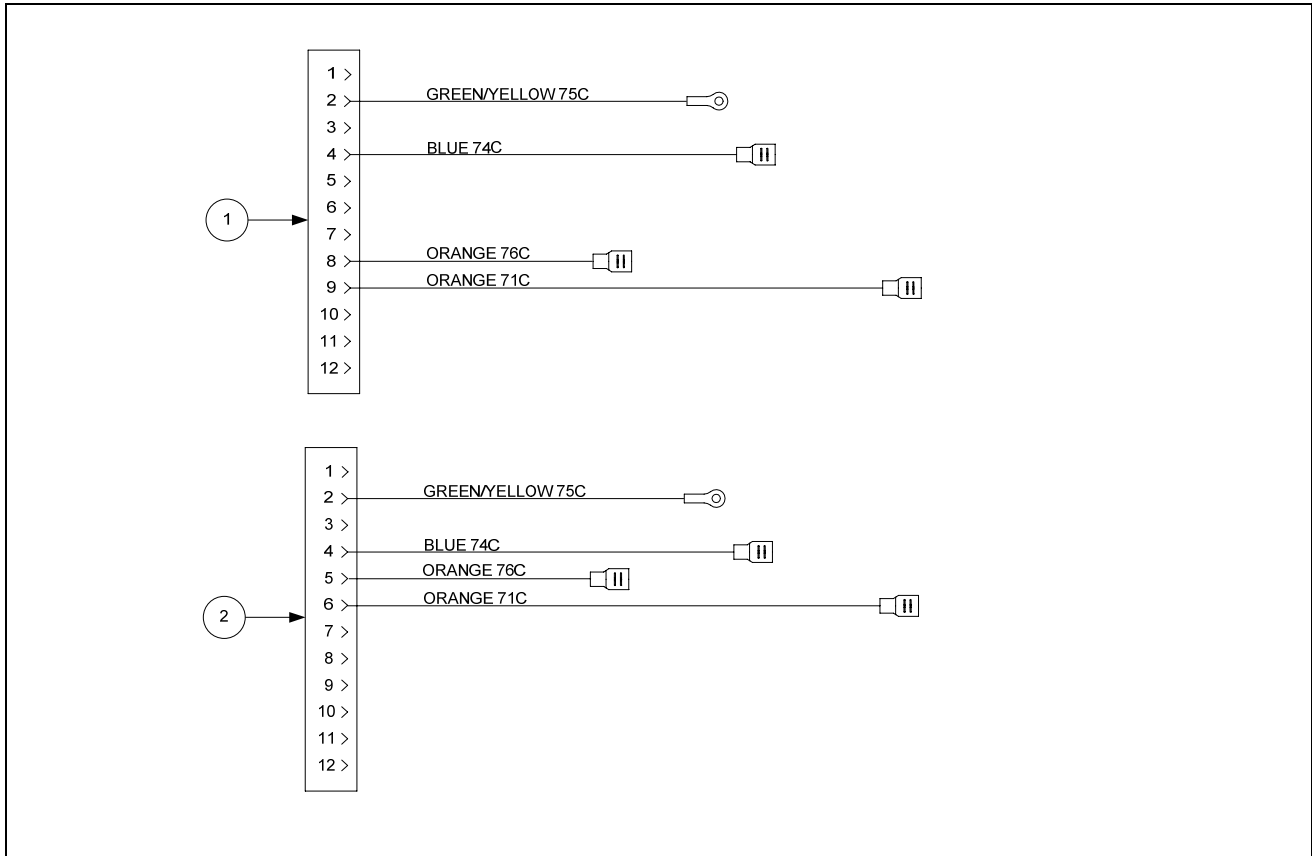

ITEM	PART #	COMPONENT
	106-6031SP	Contactor Box Harness Assembly Full Vat
1		Standard (See wiring diagrams on pages 1-19.)
		EPRI (uses harness above plus wire kits WIR0733 and WIR0736)
		(See wiring diagrams on pages 1-26 and 1-27.)
2	106-7042	Fryer and ½ Contactor Box Harness Assembly

### 2.5.7.3 Contactor Box Wiring Assemblies – 6-Pin (Left Element)

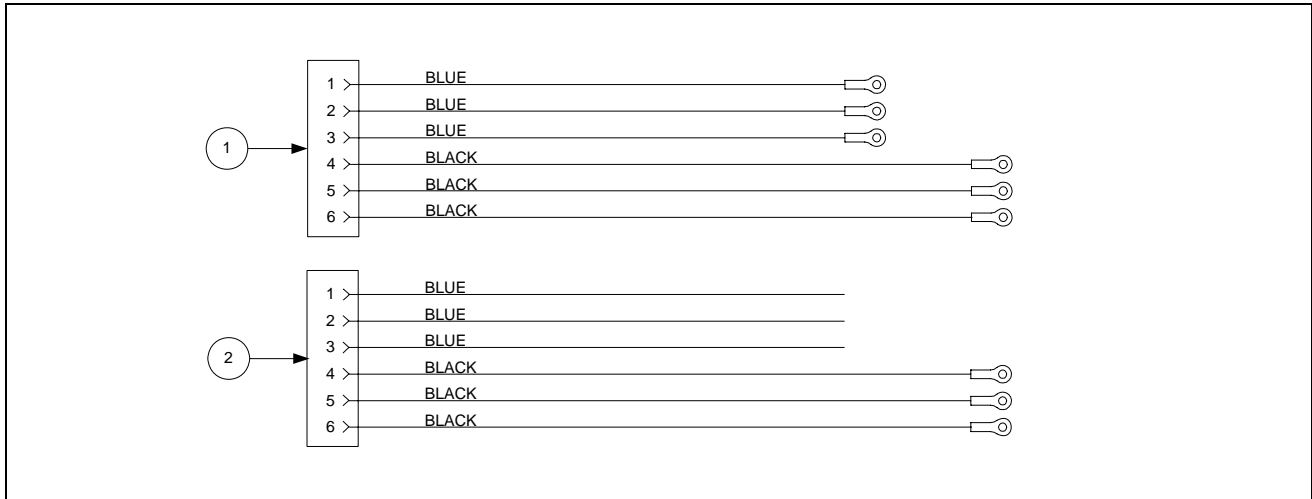

ITEM	PART #	COMPONENT
1	106-6768	14/17 kW Standard Mercury
	106-7849	22 kW Triac SSR
2	106-6771	14/17 kW Mechanical Contactor
	106-7851	22 kW Mercury and High Amp Mechanical Contactor

### 2.5.7.4 Contactor Box Wiring Assemblies – 9-Pin (Right Element)

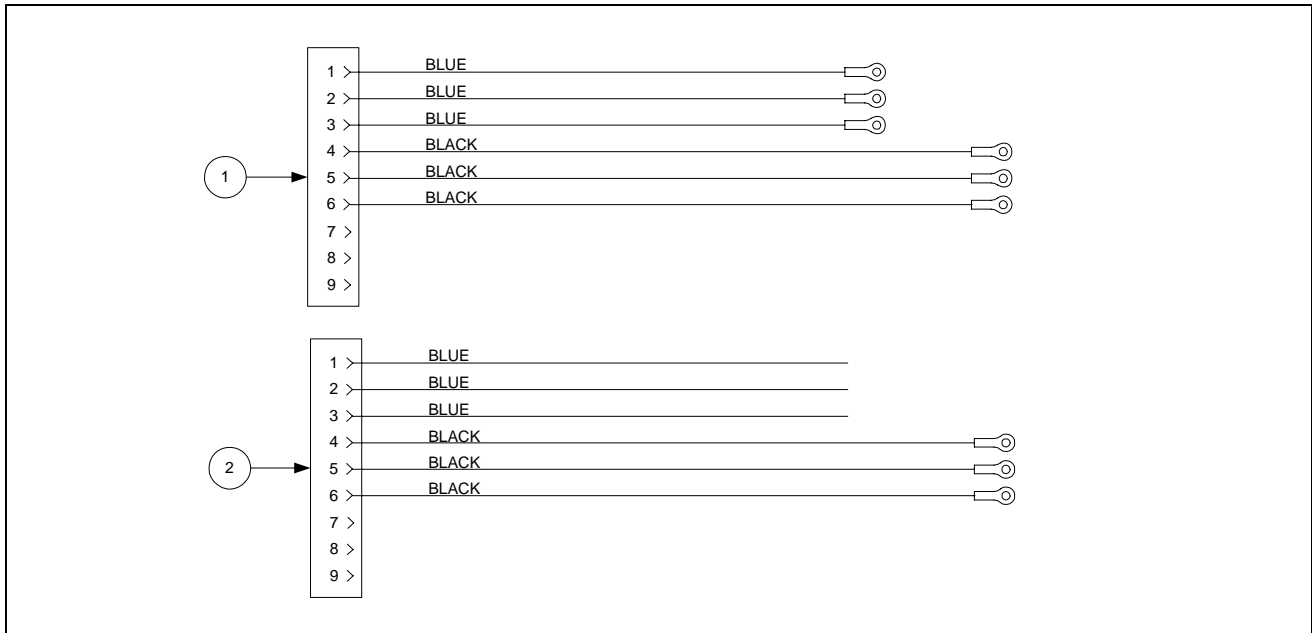

ITEM	PART #	COMPONENT
1	106-6769	14/17 kW Standard Mercury
	106-7850	22 kW Triac SSR
2	106-6772	14/17 kW Mechanical Contactor
	106-7852	22 kW Mercury and High Amp Mechanical Contactor

## 2.5.7.5 Main Wiring Harnesses - Full and Dual Vat

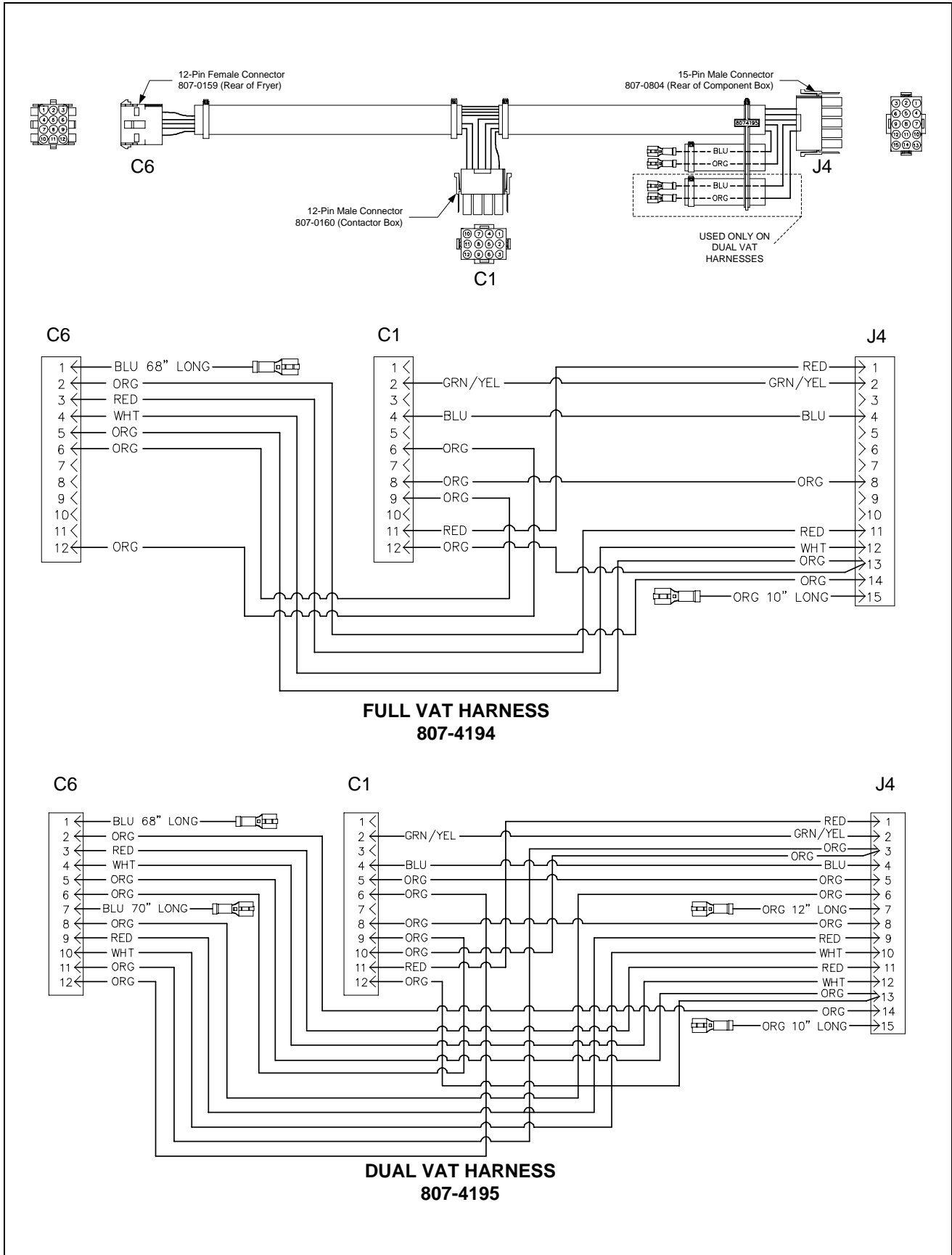

### 2.5.7.5 Main Wiring Harnesses – Fryer and ½

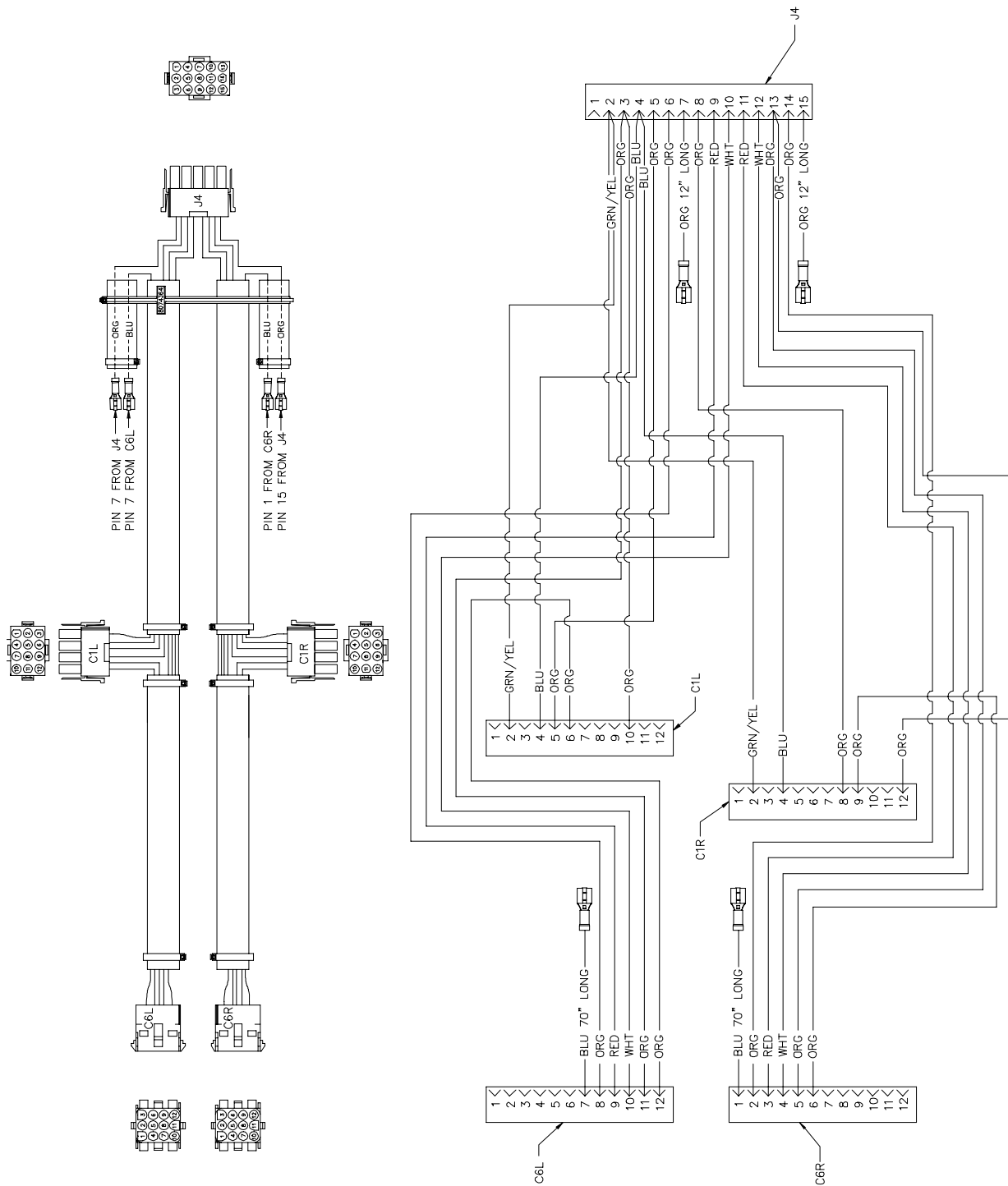

**FRYER AND ½ HARNESS  
807-4364**

## 2.5.7.6 Component Box, Filter Pump and Basket Lift Wiring Harnesses

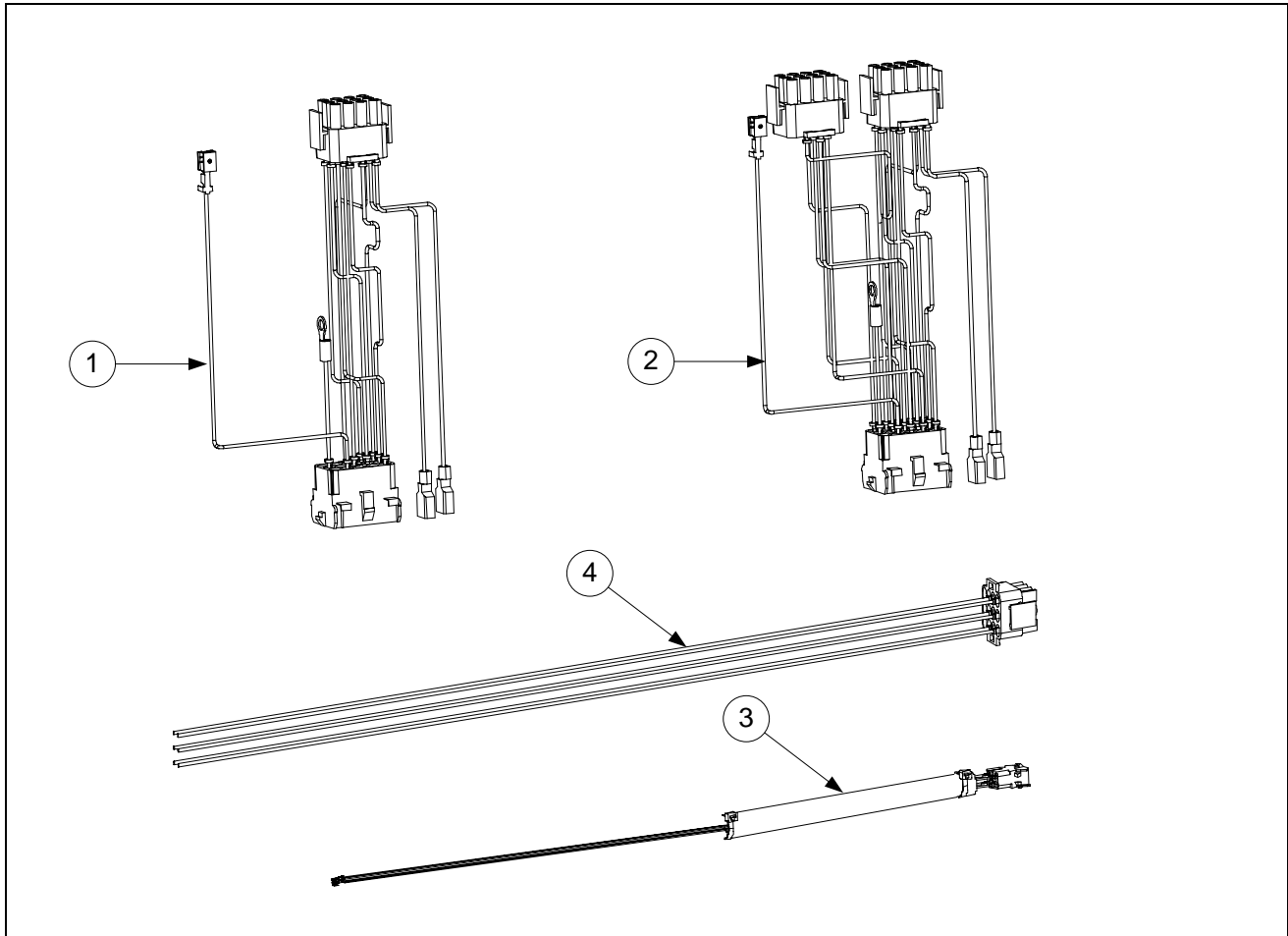

ITEM	PART #	COMPONENT
1	106-5750	Full Vat Control Harness J4 to J2 ( <i>Standard</i> )
	106-6639	Full Vat Control Harness J4 to J2 ( <i>EPRI</i> )
2	106-5751	Dual Vat Control Harness J4 to J1 and J2 ( <i>Standard</i> )
	106-6644	Dual Vat Control Harness J4 to J1 and J2 ( <i>EPRI</i> )
3	106-5935	Filter Pump C2 to Component Box Wiring Harness
4	106-5957	Basket Lift Harness Assembly ( <i>Standard</i> )
	106-6640	Basket Lift Harness Assembly ( <i>EPRI</i> )

### 2.5.7.7 Component Box to Filter Pump Harness

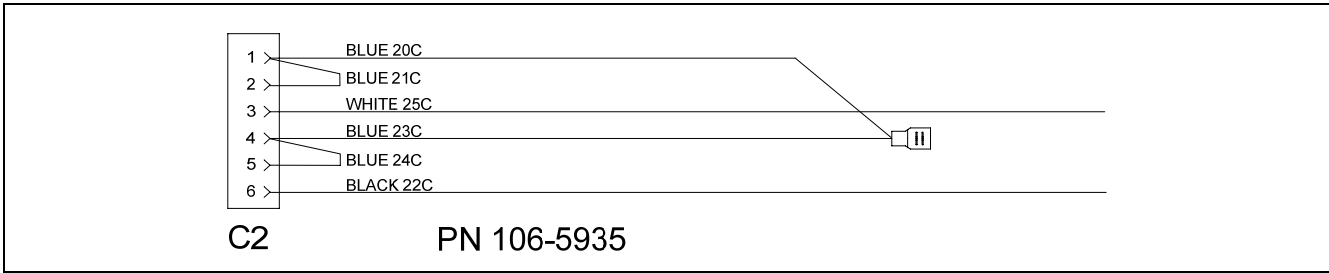

### 2.5.7.8 Basket Lift Harness

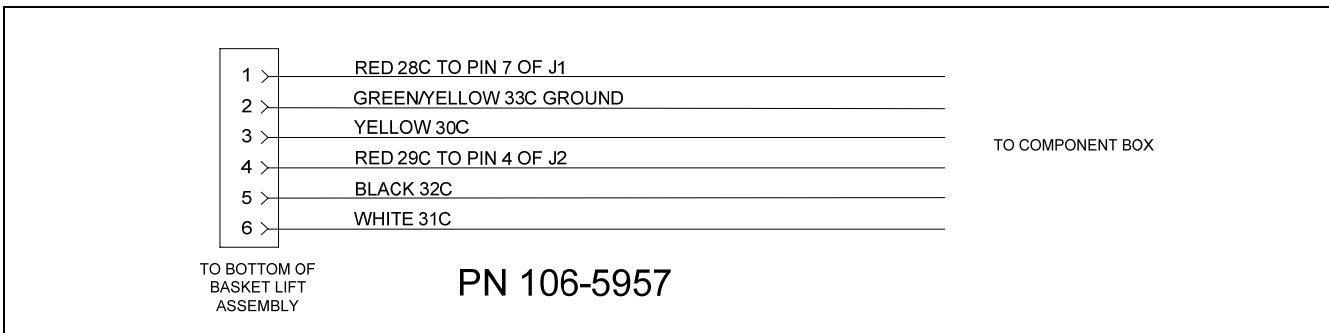

### 2.5.7.9 Interface Board to Controller Wiring Harness – 15-Pin

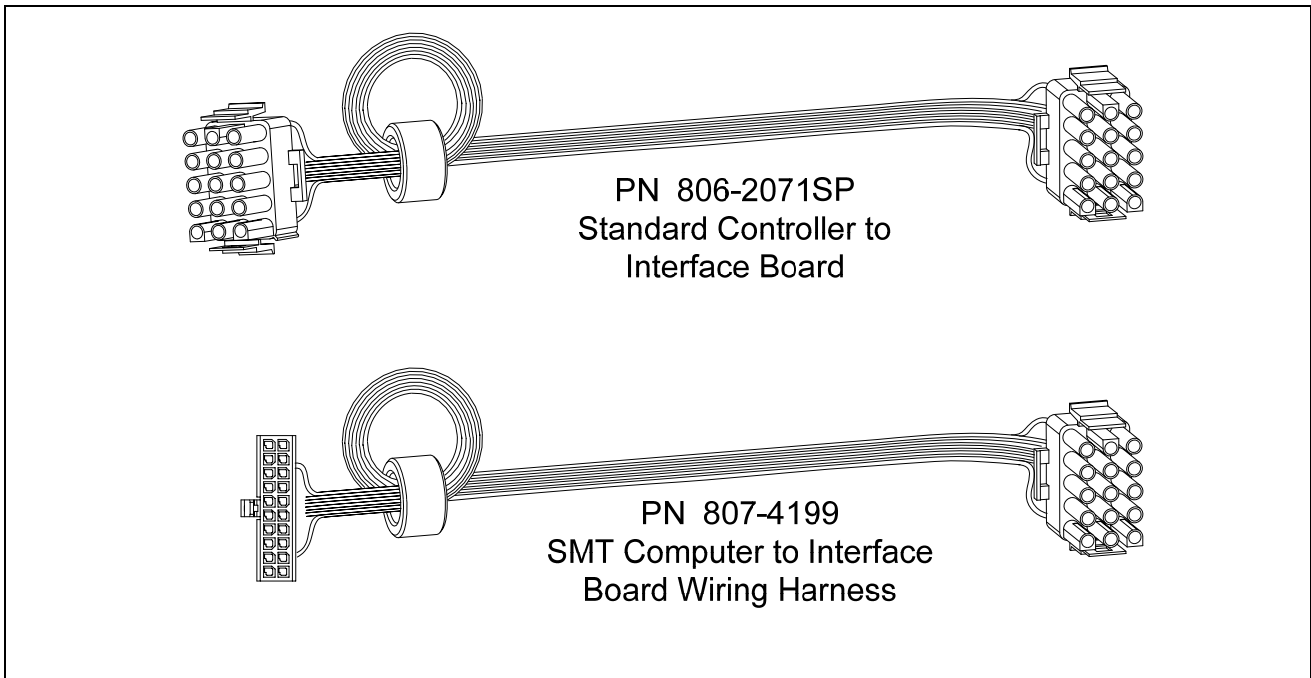

## 2.6 Filtration System Components

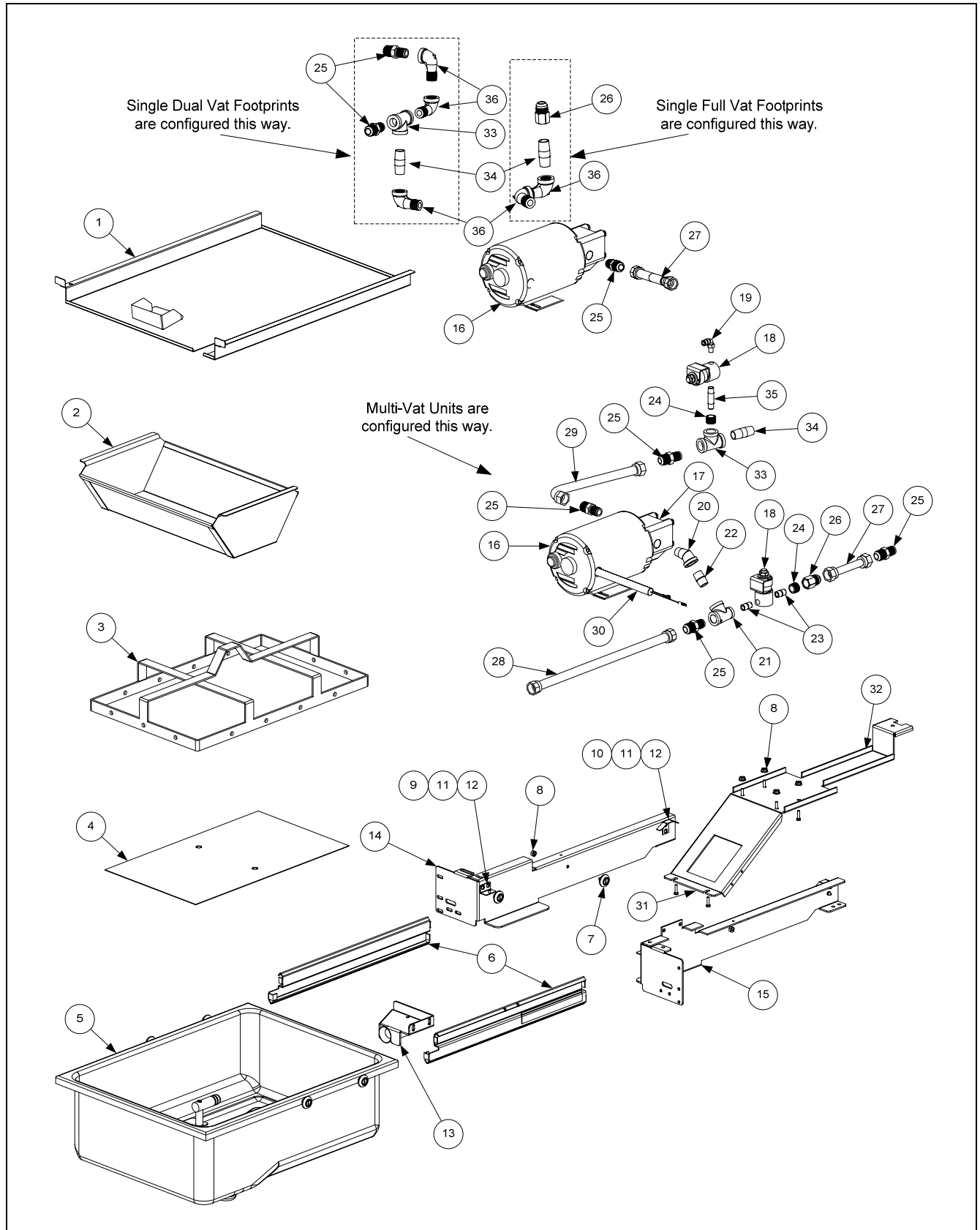

## 2.6 Filtration System Components cont.

ITEM	PART #	COMPONENT
*	826-1979	Filter Pan Roller Kit (four each of Items 7 and 8)
*	826-1980	Service Filter Pan (Item 5 minus Item 2)
*	826-1981	Service Filter Pan Assembly (Service Filter Pan above plus Items 3 and 4)
√ *	826-1392	O-Ring (Pkg. of 5; used with Item 5)
*	813-0568	Plug, 1/8-inch Socket Head Pipe (component of Item 5; two required)
*	106-5911	Heater Strip Assembly, 100-120V 25W 18" 806-5933SP
*	106-2852SP	Heater Strip Assembly, 208-250V 25W 18"
1	823-4787	Lid, Multi-Vat Fryers Filter Pan
	106-6243	Lid, Single Station Fryer Only Full Vat Filter Pan
	106-6310	Lid, Single-Station Fryer Only Dual Vat Filter Pan
	106-6461	Lid, RE SCF Deep Cabinet Filter Pan
	106-6735	Lid, Fryer 1/2 Filter Pan
2	810-2874	Crumb Tray, Multi-Vat Fryers(component of Item 5)
	824-1707	Crumb Tray, Single Station Fryer Only
	823-5812	Crumb Tray, RE SCF Deep Cabinet
	824-1734	Crumb Tray, Fryer 1/2
3	810-2910	Hold-Down Ring for Paper 13.65 x 21.41 Multi-Vat Fryers
	823-5774	Hold-Down Ring for Paper 8.98 x 19.39 Single Station Fryer Only
	823-5811	Hold-Down Ring for Pad 15.75x 20.02 SCF Deep Cabinet
	823-5934	Hold-Down Ring for Paper 8.98 x 21.04 Fryer 1/2
4	200-2124	SanaGrid Filter Screen Standard
	220-1316	SanaGrid Filter Screen, Single Station Fryer Only
	220-1461	SanaGrid Filter Screen, SCF Deep Cabinet
	220-1795	SanaGrid Filter Screen, Fryer 1/2
5	106-2617SP	Pan, One-Piece Filter Multi-Vat Fryers (includes Item 2)
	823-5594	Pan, One-Piece Filter Single Station Fryer Only
	823-5933	Pan, One-Piece Filter Fryer 1/2
	823-5798	Pan, Filter RE SCF Deep Cabinet ( <i>use 810-2805 Caster Front, 2" and 810-2807 Caster Rear 2" rigid</i> )
6	810-2012	Rail Set, Filter Pan Roller (includes one left and one right)
*	230-1381	Slide, Filter Pan SCF Deep Cabinet
√ *	826-1979	Roller Kit ( <i>includes 4 rollers, 4 nuts and 4 lock washers</i> )
7	810-2198	Roller, Filter Pan and Rail
8	826-1372	Nut, 1/4-20 Hex (Pkg. of 10)
*	809-0191	Washer, Lock 1/4 Spring ZP
9	823-4675	Bracket, Lid Support
10		Guide, Filter Pan Lid
	200-3556	Left
	200-6709	Right
11	809-0503	Screw, 8-32 X 1/2-inch Slotted Truss Head
12	809-0247	Nut, 8-32 Hex Keps
13	823-3879	Suction Tube, Multi-Vat Fryer
	823-5591	Suction Tube, Single-Station Fryer

\* Not illustrated.

*Continued on next page...*

√ Recommended parts.

## 2.6 Filtration System Components cont.

ITEM	PART #	COMPONENT
14	200-4408	Rail, Left Pan Filter Multi-Vat Fryers
	106-5981	Support Assembly, Left Single Station Fryer Only
	220-1378	Support, Left Filter Pan SCF Deep Cabinet
	220-2069	Support, Left Filter Pan Fryer ½
15	200-4409	Rail, Right Filter Pan Multi-Vat Fryers
	106-5982	Support Assembly, Right Single Station Fryer Only
	220-1379	Support, Right Filter Pan SCF Deep Cabinet
	220-2070	Support, Right Filter Pan Filter ½
16		Motor and Gasket Kit
	826-1785	100V 50/60 Hz
√	826-1712	115V 50/60 Hz
√	826-1756	208V 50/60 Hz
	826-1270	220-240V 50/60 Hz
	826-1755	250V 50/60 Hz
√ 17	826-1264	Pump and Gasket Kit 4 GPM 2-piece
	816-0093	Gasket, Pump/Motor
*	807-11973	Seal Kit, Pump Viking
	810-2902	Pump, Viking 8 GPM SCF Deep Cabinet
√ 18	807-2484	Valve, ¼-inch Solenoid
19	810-2493	Fitting, ¼-inch x 90° Quick-Connect
*	811-1071	Tubing, ¼-inch OD Teflon Vent (sold by the foot)
20	813-0342	Elbow, ½-inch 45° Street
21	813-0530	Tee, ½-inch X ¼-inch X ½-inch Reducing
22	813-0022	Nipple, ½-inch Close
23	813-0838	Nipple, ¼-inch Close
24	813-0304	Bushing, ½-inch to ¼-inch Flush
25	810-1668	Adapter, ⅝-inch to ½-inch NPT Male
26	810-1669	Adapter, ⅝-inch to ½-inch NPT Female
27	810-1680	Flexline, 6.5-inch Oil Return
28	810-1057	Flexline, 13-inch Oil Return
29	810-1043	Flexline, 9.5-inch Oil Return
30		Wiring Harness, Filter Pump
	106-5910	115/120V Filter Harness
	106-5906	208/230/240/250V Filter Harness
31	809-0401	Screw, 10-32 X ¾-inch Hex Trim Head (Pkg. of 5)
32	200-7112	Bridge, Filter Motor Multi-Vat Fryers
	824-1705	Bridge Filter Motor Single Station Fryer Only
	220-1346	Bridge, Filter Motor SCF Deep Cabinet
	220-2080	Bridge, Filter Motor Fryer ½, Half Fryer LH side
	220-1837	Bridge, Filter Motor Fryer ½, Half Fryer RH side
33	813-0003	Tee, ½-Inch
34	813-0298	Nipple, ½-inch 2.0-inch
35	813-0537	Nipple, ¼-inch 2.0-inch
36	813-0165	Elbow, ST ½-inch x ½-inch NPT 90° BM

\* Not illustrated.

√ Recommended parts.

## 2.7 Frypot Assemblies and Associated Parts

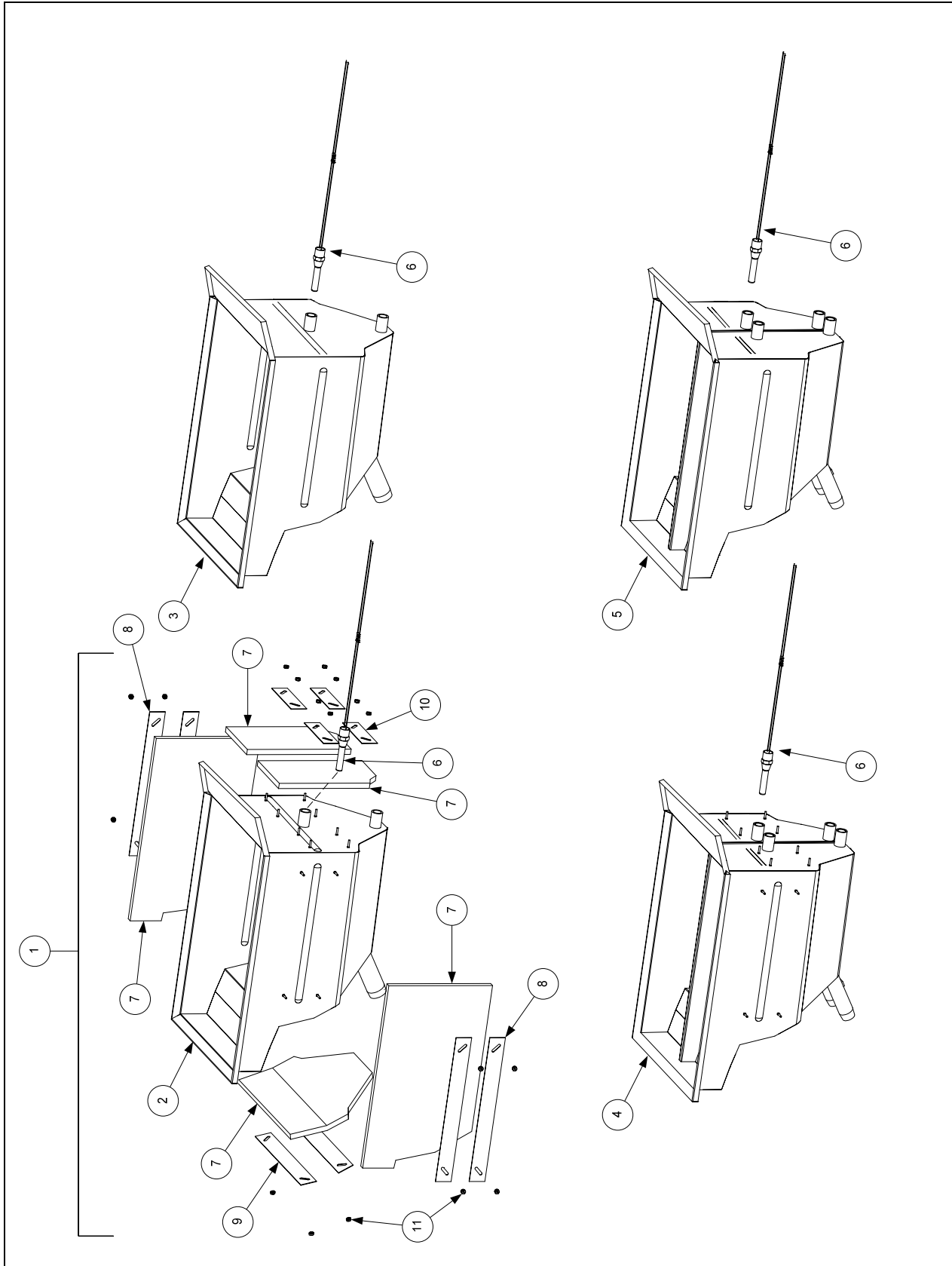

## 2.7 Frypot Assemblies and Associated Parts cont.

ITEM	PART #	COMPONENT
1		Frypot Assembly <i>(does not include Item 6)</i>
2	823-5545SP	Frypot, Full-Vat Filter with Insulation <i>(for use on EPRI units)</i>
3	823-5359SP	Frypot, Full-Vat Filter w/o Insulation <i>(for use on Standard units)</i>
	823-5996	Frypot, Half-Vat Filter w/o Insulation LH <i>(for use on Fryer 1/2 LH units)</i>
	823-5723	Frypot, Half-Vat Filter w/o Insulation RH <i>(for use on Fryer 1/2 RH units)</i>
	823-5783	Frypot, Full-Vat Filter w/o Insulation Deep Cabinet <i>(for use on Standard Deep units)</i>
4	823-5551SP	Frypot, Dual-Vat Filter with Insulation <i>(for use on EPRI units)</i>
5	823-5482SP	Frypot, Dual-Vat Filter w/o Insulation <i>(for use on Standard units)</i>
√ 6		Thermostat Assembly, High-Limit
	826-2454	Non-CE Full Vat 425°F (218°C) (17kW FV and 14kW FV)(Color-Coded Black 806-7543)
	826-2456	Non-CE Dual Vat 435°F (224°C) (22kW, 17kW DV and 14 kW DV) (Color-Coded Red 806-8035)
	826-2455	CE 415°F (213°C) (14kW and 17kW CE) (Color-Coded Yellow 806-8132)
	826-2457	CE 405°F (207°C) (22 kW FV and DV CE) (Color-Coded White 806-8536)
7	812-0211	Insulation, Kaowool 17-inch X 10-inch X 1/2-inch (4 required per pot)
8	900-4100	Retainer, Side Insulation
9	900-4101	Retainer, Front Insulation
10	900-1345	Retainer, Rear Insulation
11	826-1376	Nut, 10-32 Keps Hex (Pkg. of 10)

**NOTES:** The frypots for EPRI-equipped units are insulated; those for non-EPRI (standard) units are not. EPRI frypot assemblies 806-5545SP and 806-5551SP consist of Items 2 and 4 respectively, plus insulation (Items 7-10). When replacing insulation or adding insulation to a bare frypot, the individual pieces (sides, front, and back) are cut to fit from Item 7 when installed. Each frypot requires four uncut pieces of insulation.

√ Recommended parts.

## 2.8 Oil Return System Components

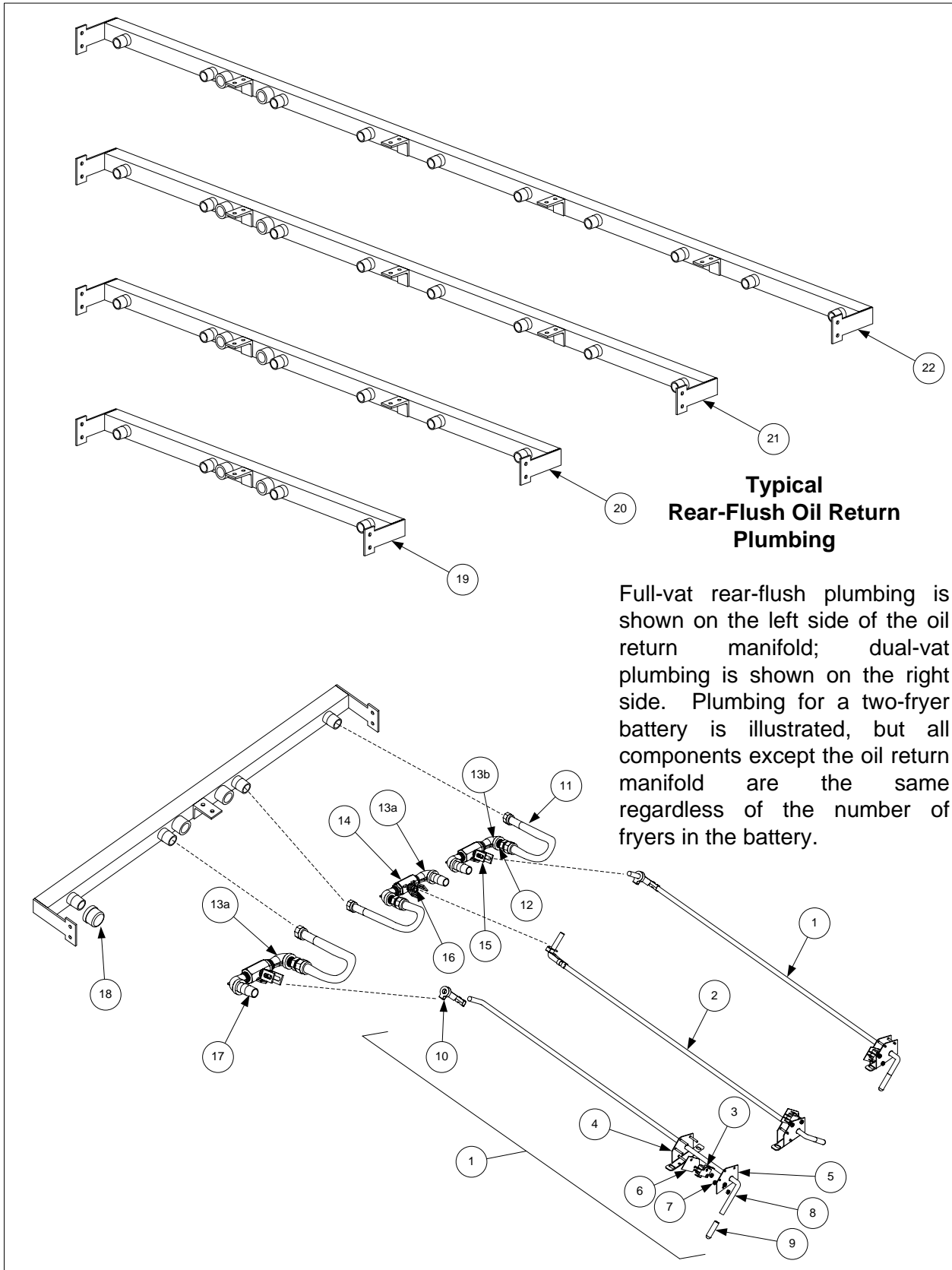

## 2.8 Oil Return System Components cont.

ITEM	PART #	COMPONENT
1	106-5596	Handle Assembly, Full-Vat and Right Dual-Vat Rear Flush Complete
	106-6410	Handle Assembly, Full-Vat Deep Cabinet Complete
2	106-5597	Handle Assembly, Left Dual-Vat Rear Flush Complete
3	807-2103	Microswitch, Straight Lever
4	106-5595	Bracket Assembly, Microswitch
5	200-5401	Bracket, Handle Retainer
6	816-0220	Insulation, Oil Return Microswitch
7	826-1366	Nut, 4-40 Keps Hex (Pkg. of 25)
8	810-2534	Rod, Full-Vat and Right Dual Vat Rear Flush
	810-3081	Rod, Full-Vat Right Hand Deep Cabinet
	810-2533	Rod, Left Dual Vat Rear Flush
9	816-0643	Grip, Oil Return Valve Handle
10	809-0601	Clip, Clevis
11	810-2532	Flexline, 7.0-inch Multi-Vat Units
	810-1057	Flexline, 13.0-inch Single Footprint Only Full Vat and Dual Vat Left Side
	810-1055	Flexline, 11.5-inch Single Footprint Only Dual Vat Right Side
12	810-1668	Adapter, 5/8-inch to 1/2-inch NPT Male
13a	813-0165	Elbow, 1/2-inch X 90° Street
*	813-0062	Elbow, 1/2-inch X 90° BM
*	813-0087	Nipple, 1/2-inch X 1.50-inch NPT
13b	813-0908	Adapter, 1/2-inch NPT M/T 90° ( <i>used only on cabinet side</i> )
14	810-0278	Valve, 1/2-inch Ball
15	200-5438	Handle, Rear Flush Valve
16	900-2935	Retainer, Oil Return Valve Nut
17	813-0460	Nipple, 1/2-inch X 3.0-inch NPT
18	813-0907	Cap, 15/16-inch Valve Safety
		Manifolds
*	810-3142	Manifold, Fryer 1/2 Station Fryer
19	810-3015	Manifold, Two-Station Fryer ( <i>use 810-2543 for non-filter units</i> )
20	810-3016	Manifold, Three-Station Fryer ( <i>use 810-2544 for non-filter units</i> )
21	810-3017	Manifold, Four-Station Fryer ( <i>use 810-2545 for non-filter units</i> )
22	810-3018	Manifold, Five-Station Fryer ( <i>use 810-2546 for non-filter units</i> )

\* Not illustrated.

## 2.9 Oil Disposal Plumbing

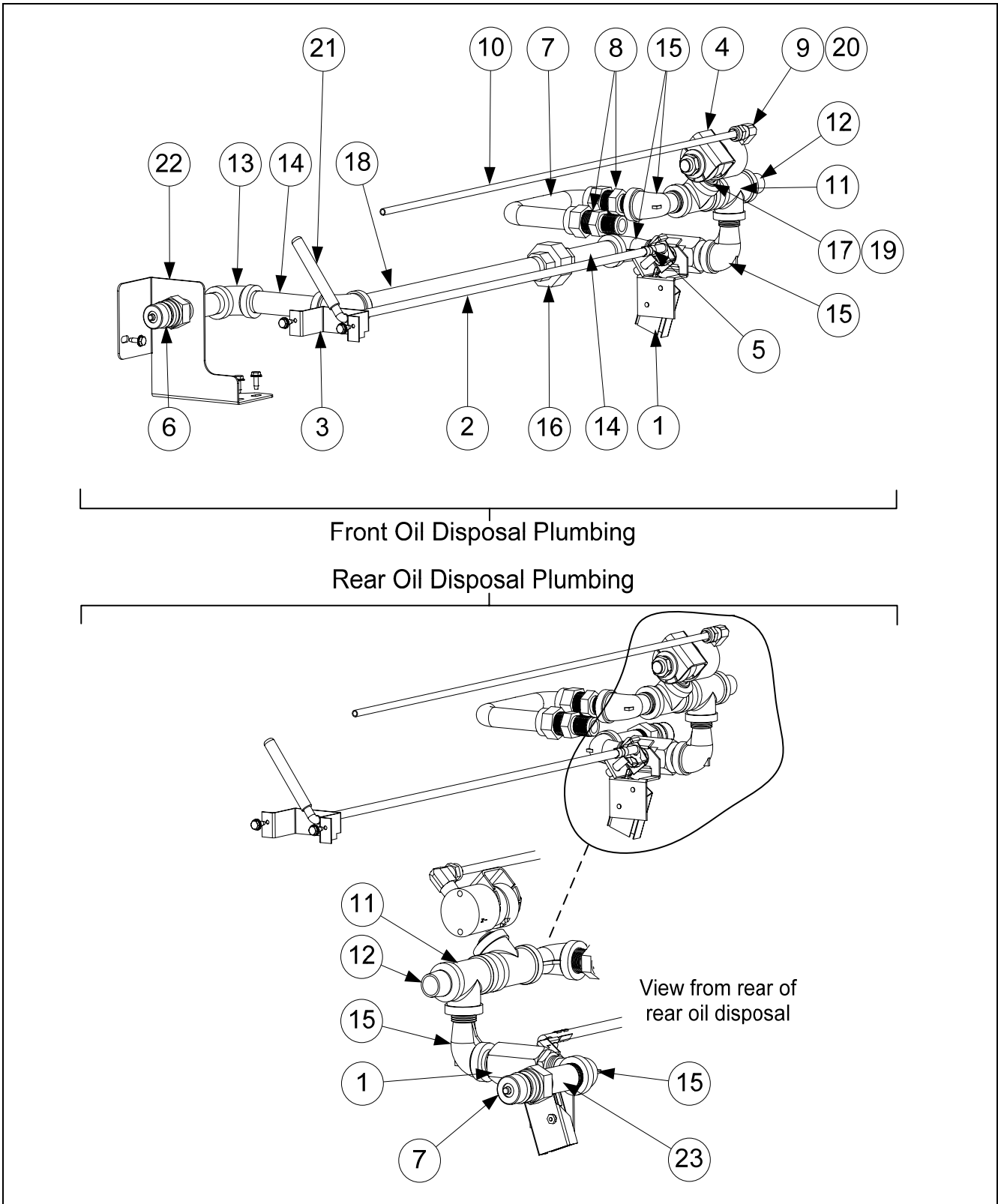

## 2.9 Oil Disposal Plumbing cont.

ITEM	PART #	COMPONENT
	106-5959	Plumbing, Front Oil Disposal
	106-5933	Plumbing, Rear Oil Disposal
1	106-6033	Valve Assembly, Oil Disposal
2	220-0922	Rod, Oil Disposal
3	220-0963	Bracket, Oil Disposal Rod
4	807-2484	Valve, Solenoid 1/4-inch NPT
5	809-0601	Clip, Clevis Right Rod End
6	810-0487	Coupling, Male
7	810-1043	Flexline, 1/2-inch ID x 9.50"
*	810-1055	Flexline, 1/2-inch ID x 11.50"
8	810-1668	Adaptor, Male 5/8-inch OD x 1/2-inch
9	810-2493	Fitting, 90° Quick Connect Tube
10	811-1071	Tubing, 1/4-inch OD (sold by the foot)
11	813-0003	Tee, 1/2-inch x 1/2-inch x 1/2-inch BM
12	813-0022	Nipple, 1/2-inch x Close NPT BM
13	813-0062	Elbow, 1/2-inch 90° BM
14	813-0093	Nipple, 1/2-inch x 4.0" NPT BM
15	813-0165	Elbow, Street 1/2-inch x 1/2-inch NPT 90° BM
16	813-0173	Union, 1/2-inch NPT BM
17	813-0304	Bushing, 1/2-inch x 1/4-inch BM Flush
18	813-0429	Nipple, 1/2-inch x 13.0" NPT BM
19	813-0571	Nipple, 1/4-inch x 1 1/2-inch BM
20	813-0807	Bushing, 1/4-inch x 1/8-inch
21	816-0637	Cap, Vinyl Blue 5/16-inch x 3.0"
22	823-5685	Bracket, Assembly Quick Disconnect
	823-5809	Bracket, Assembly Quick Disconnect SCF Deep Cabinet
23	813-0265	Nipple, 1/2-inch x 2.50" NPT BM
*	810-1669	Adapter, Female 7/8-inch O.D. x 1/2-inch
*	813-0253	Nipple, 1/2-inch x 10.00" NPT BM
*	813-0298	Nipple, 1/2-inch x 2.00" NPT BM
*	106-6407	Switch Assembly RE Wand

\* Not illustrated.

## 2.10 Oil Disposal Wand

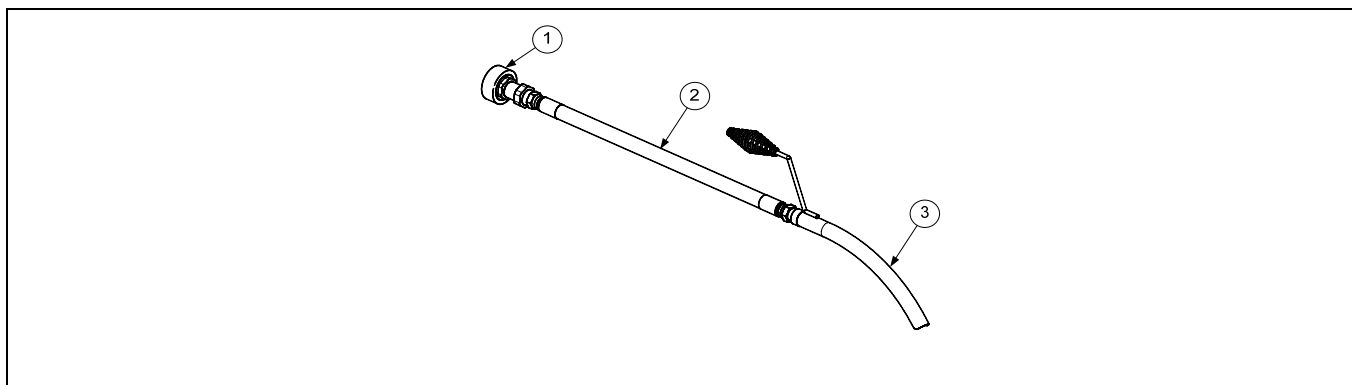

ITEM	PART #	COMPONENT
	106-4395	Oil Disposal Wand Assembly
1	810-0490	Quick Disconnect 1/2-inch Female
2	810-1471	Hose, 24-inch
3	810-0603	Wand

## 2.11 Wiring Connectors and Pin Connectors

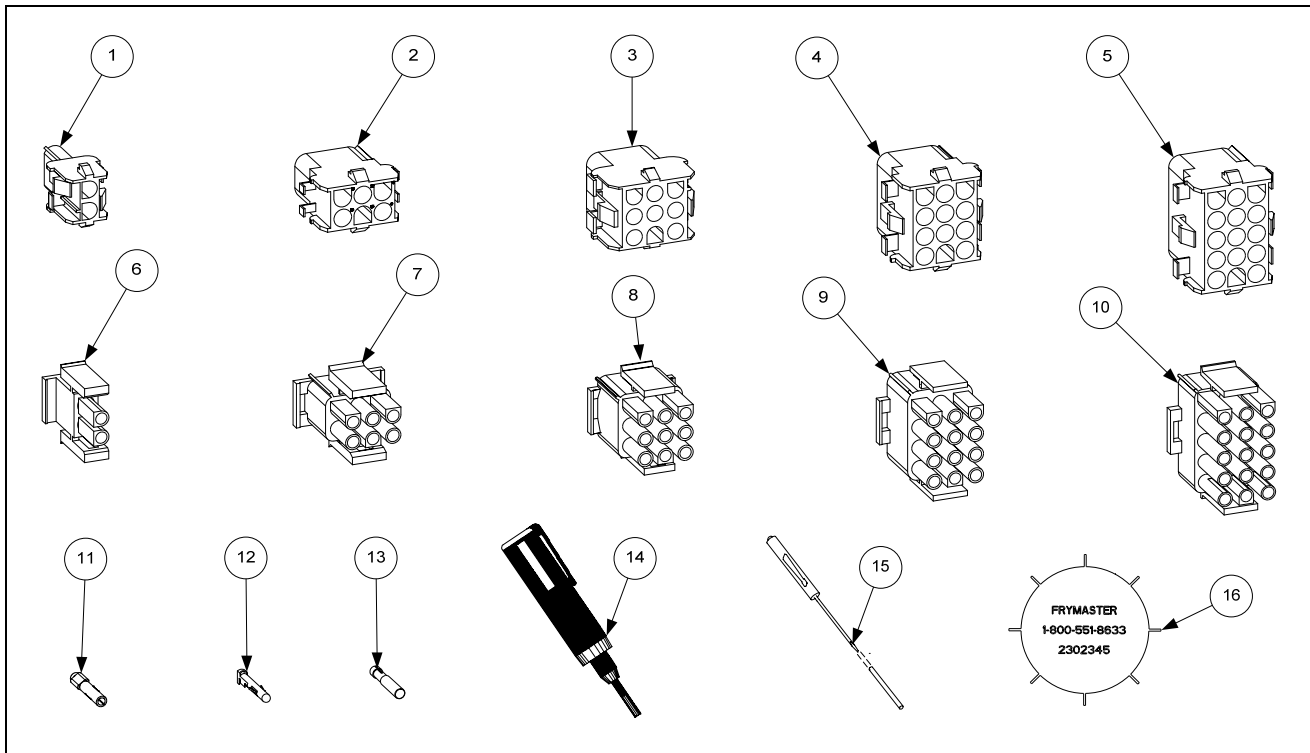

ITEM	PART #	COMPONENT
1	807-1068	2-Pin Female
2	807-0158	6-Pin Female
3	807-0156	9-Pin Female
4	807-0159	12-Pin Female
5	807-0875	15-Pin Female
6	807-1067	2-Pin Male
7	807-0157	6-Pin Male
8	807-0155	9-Pin Male
9	807-0160	12-Pin Male
10	807-0804	15-Pin Male
11	826-1341	Terminal, Female Split Pin (pkg. of 25)
12	826-1342	Terminal, Male Split Pin (pkg. of 25)
13	807-2518	Plug, Mate-N-Lock (Dummy Pin)
√ 14	807-0928	Extract Tool Pin Pusher
√ 15	806-4855	Pin Pusher Screwdriver Assembly
√ 16	230-2345	SMT Pin Extractor
√ *	807-4660PK	SMT Pin Service Repair Kit

\* Not illustrated.

√ Recommended parts.

## 2.12 Fasteners

ITEM	PART #	COMPONENT
*	809-0429	Bolt, 1/4-inch – 20 x 2.00-inch Hex Head ZP Tap
*	809-0514	Capscrew, 5/16-inch-18 NC Hex
*	809-0448	Clip, Tinnerman
*	826-1366	Nut, 4-40 Keps Hex (Pkg. of 25) (809-0237)
*	826-1358	Nut, 6-32 Keps Hex (Pkg. of 25) (809-0049)
*	809-0247	Nut, 8-32 Keps Hex
*	826-1376	Nut, 10-32 Keps Hex (Pkg. of 10) (809-0256)
*	809-0766	Nut, 10-32 Keps Hex SS
*	809-0581	Nut, 1/2 NPT Locking
*	809-0020	Nut Cap 10-24 NP
*	826-1372	Nut Grip 1/4-inch 1/4-20 Hex NP (Pkg. of 10) (809-0059)
*	809-0417	Nut Flange 1/4-inch 1/4-20 Serr
*	809-0535	Nut, "T" 1/4-inch-20 x 7/16 SS
*	809-0540	Nut, Lock 1/2-inch-13 Hex 2-Way ZP
*	826-1359	Screw, 4-40 x 3/4-inch Slotted Round Head (Pkg. of 25) (809-0354)
*	826-1365	Screw, 6-32 x 3/8-inch Slot Head (Pkg. of 25) (809-0095)
*	809-0357	Screw, 6 x 3/8-inch Phillips Head NP
*	809-0359	Screw, 8 x 1/4-inch Hex Washer Head
*	809-0360	Screw, 8 x 3/8-inch Hex Washer Slot Head
*	826-1371	Screw, 8 x 1/2-inch Hex Head ZP (Pkg. of 25) (809-0361)
*	809-0364	Screw, 8 x 5/8-inch Hex Washer Head ZP
*	809-0518	Screw, 8-32 x 3/8-inch Hex Washer Slotted Head SS
*	809-0104	Screw, 8-32 x 1/2-inch Slotted Head ZP
*	826-1363	Screw, 8-32 x 1/2-inch NP (Pkg. of 25) (809-0103)
*	826-1360	Screw, 10-24 x 5/16-inch Round Slot Head ZP (Pkg. of 25) (809-0024)
*	826-1330	Screw, 10-32 x 3/8-inch Slot Head SS (809-0117)
*	809-1003	Screw, 10-32 x 3/8-inch Hex Trim Head SS
*	826-1375	Screw, 10-32 x 3/4-inch Hex Trim Head SS (Pkg. of 5) (809-0401)
*	809-1000	Screw, 10-32 x 1 1/4-inch Hex Sck C/S
*	826-1374	Screw, 10 x 1/2-inch Hex Head (Pkg. of 25) (809-0412)
*	809-0266	Screw, 10 x 1/2-inch Phillips Head ZP
*	809-0434	Screw, 10 x 3/8-inch Hex Washer Head NP
*	809-0123	Screw, 10 x 3/4-inch Slot Head
*	826-1389	Screw, 1/4-20 x 3/4-inch Hex Head ZP (Pkg. of 10) (809-0131)
*	809-0582	Washer 1/2 NPT Locking
*	809-0184	Washer, #10 LK ZP
*	809-0190	Washer, .625 X .275 X 40 Flat SS
*	809-0191	Washer, Lock 1/4 Spring ZP
*	809-0193	Washer, Flat 1/4 Nylon
*	809-0194	Washer, Flat 5/16 ZP

**THIS PAGE INTENTIONALLY LEFT BLANK**



Frymaster, L.L.C., 8700 Line Avenue, Shreveport, Louisiana 71106

TEL 1-318-865-1711

FAX (Parts) 1-318-219-7140

(Tech Support) 1-318-219-7135

PRINTED IN THE UNITED STATES

SERVICE HOTLINE  
1-800-551-8633

819-6150  
MAY 2009